

Area	JAPAN	NORTH AMERICA	LATIN AMERICA	EUROPE	GENERAL AREA	CHINA
Model Name	KJ-77A9G	XBR-77A9G	XBR-77A9G	KD-77AG9	KD-77A9G	KD-77A9G
SV No.	SV-36291	SV-36288(UC2)	SV-36288(LA1)	SV-36293	SV-36294	SV-36290
DIMENSION	TV only (WxHxD)	172.1x99.6x4.9(0.69) cm	1721x996x49(6.9) mm / 67 7/8 x 39 1/4 x 1 15/16(9/32) inch	1721x996x49(6.9) mm	Approx. 172.1x99.6x4.9(0.69) cm	Approx. 1721x996x49(6.9) mm
	TV with Stand (WxHxD)	172.1x100.1x30.2 cm	1721x1001x302 mm / 67 7/8 x 39 1/2 x 12 inch	1721x1001x302 mm	Approx. 172.1x100.1x30.2 cm	Approx. 1721x1001x302 mm
	Media Receiver (WxHxD)	-	-	-	-	-
	Monitor only (WxHxD)	-	-	-	-	-
	Monitor with Stand (WxHxD)	-	-	-	-	-
	Media Receiver with Stand (WxHxD)	-	-	-	-	-
	Satellite Speaker (WxHxD)	-	-	-	-	-
	Stand Width	50.0 cm	500 mm / 19 3/4 inch	500 mm	Approx. 50.0 cm	Approx. 500 mm
	VESA Hole Pitch	30.0x30.0 cm	300x300 mm / 11 7/8 x 11 7/8 inch	300x300 mm	30.0x30.0 cm	300x300 mm
WEIGHT	TV Only	35.3 Kg	35.3 Kg / 77.8 lb	35.3 Kg	Approx. 35.3 Kg	Approx. 35.3 Kg
	TV With Stand	39.7 Kg	39.7 Kg / 87.5 lb	39.7 Kg	Approx. 39.7 Kg	Approx. 39.7 Kg
	Media Receiver	-	-	-	-	-
	Monitor Only	-	-	-	-	-
	Monitor With Stand	-	-	-	-	-
	Media Receiver with Stand	-	-	-	-	-
	Satellite Speaker	-	-	-	-	-
Remarks						

TV WITH STAND

WITHOUT COVER

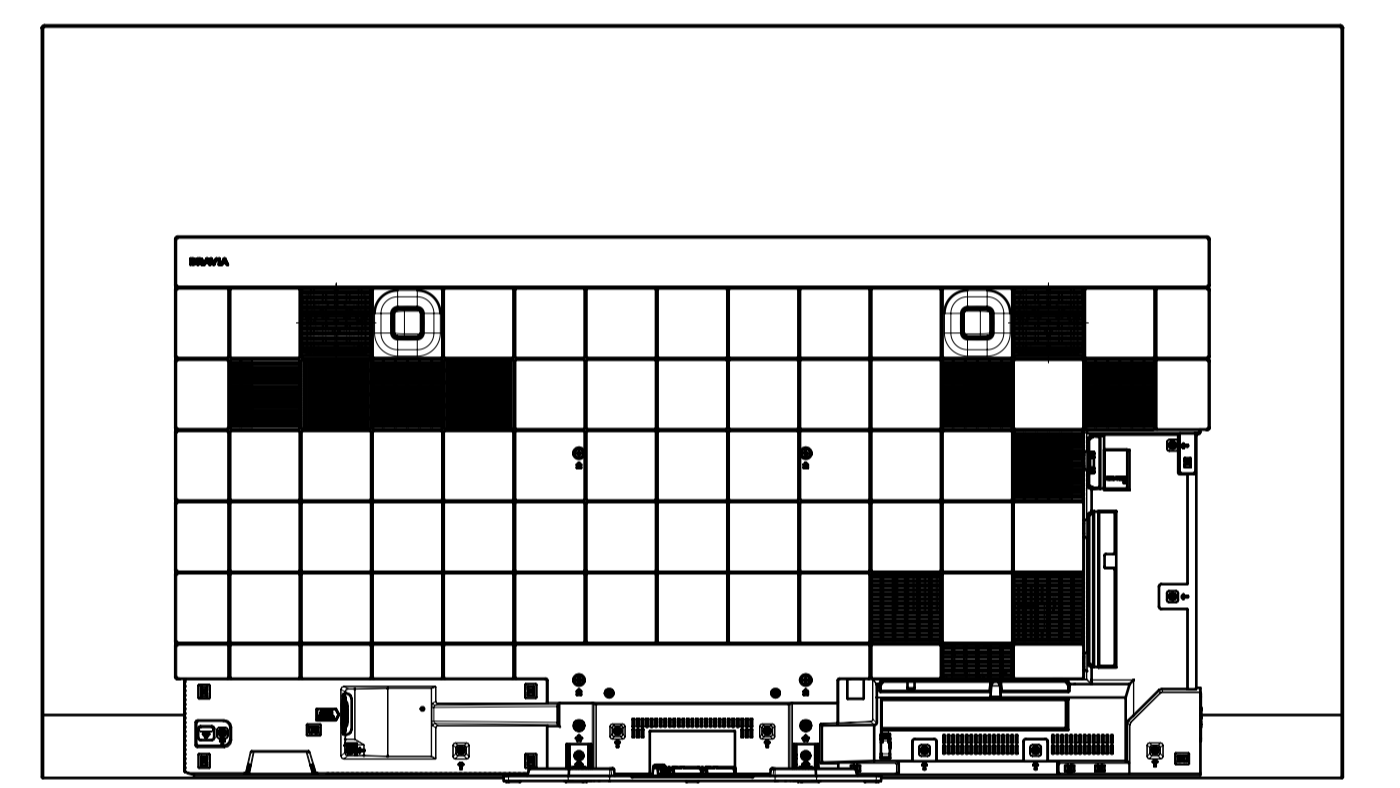
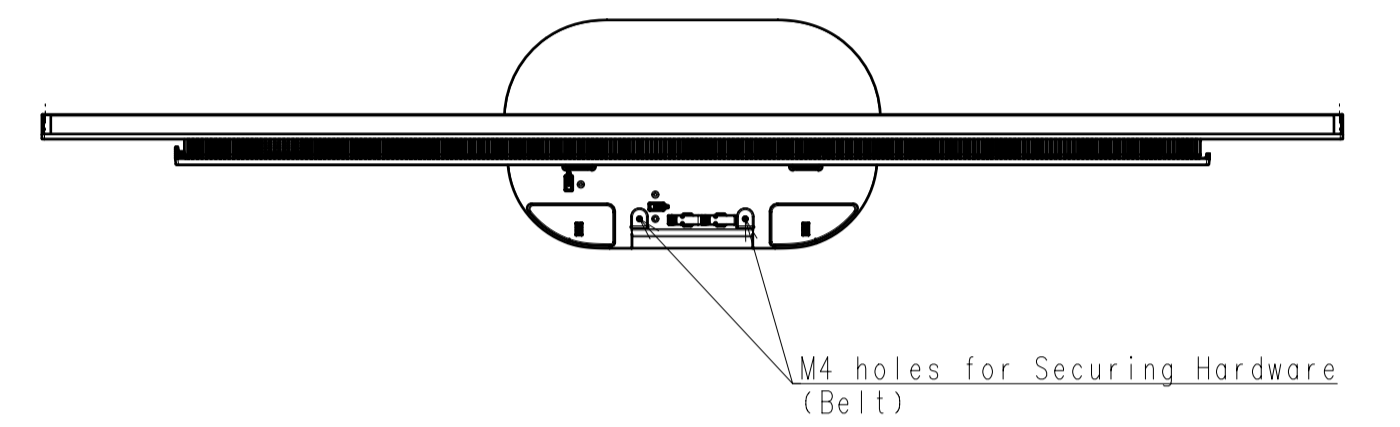
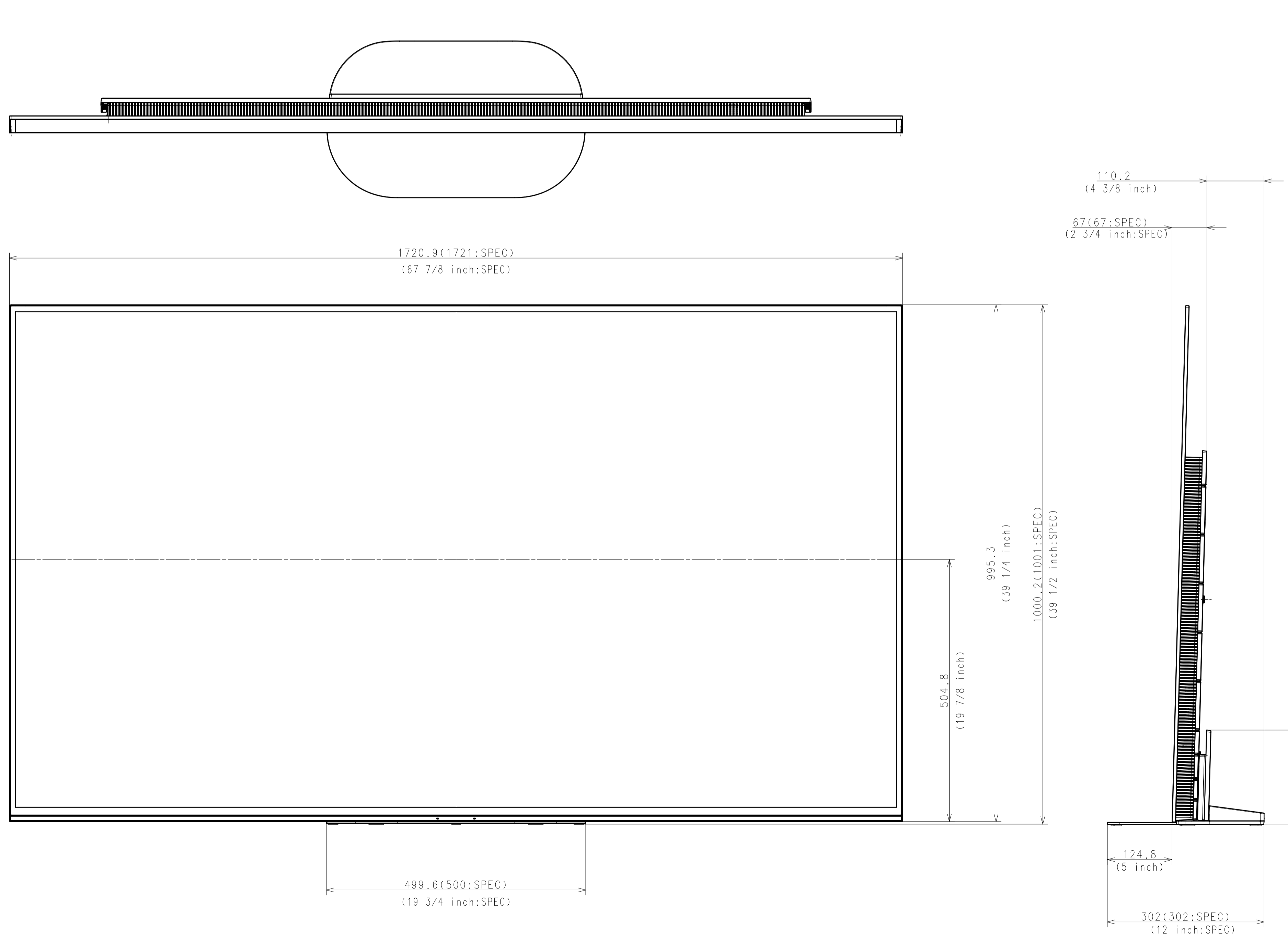

WITH COVER

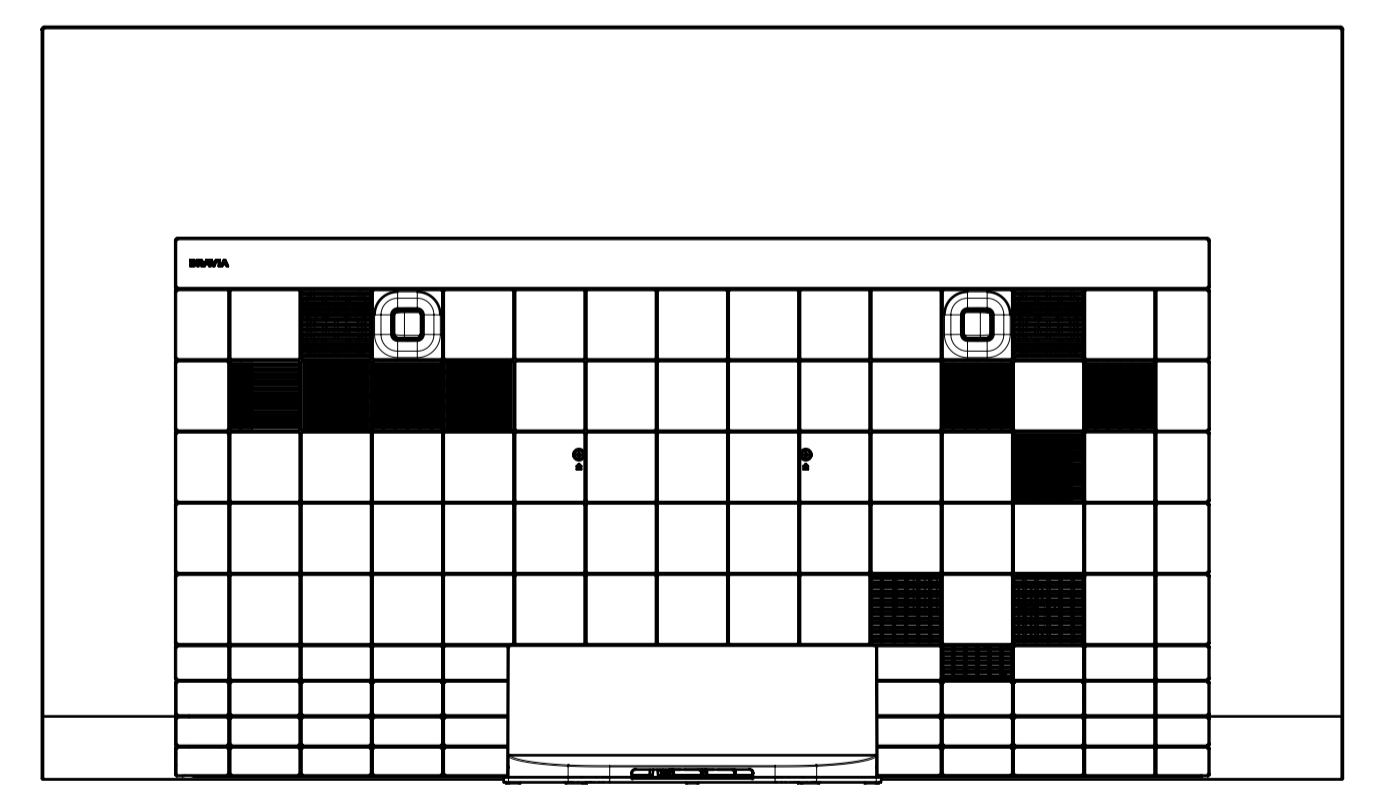

Purchase recycled resins and wire rods only from the business partners that Sony approves as Green Partners.

DATE OF ISSUE	2019.02.12
DOCUMENT TYPE	PART DRAWING
TOLERANCING	(JIS & ISO/IEC15010)
MATERIAL COLOR	
FINISH COLOR	
RESPONSIBLE DEPARTMENT	SVP-TV B Div. PD Div. PD Dept. 3
ORIGINAL MODEL	77 (A9G) EXTERIOR VIEW
PLANNED BY	S. SENOGOKU
DESIGNED BY	S. SENOGOKU
APPROVED BY	
SCALE	1:5
TENTATIVE MODEL	77 (A9G) EXTERIOR VIEW
PREL. METHOD	A1
SIZE	A1
UNIT	mm
PART NO.	
SUFFIX	
REV. NO.	1 / 5
SHEET/PAGES	1 / 5

TV WITHOUT STAND

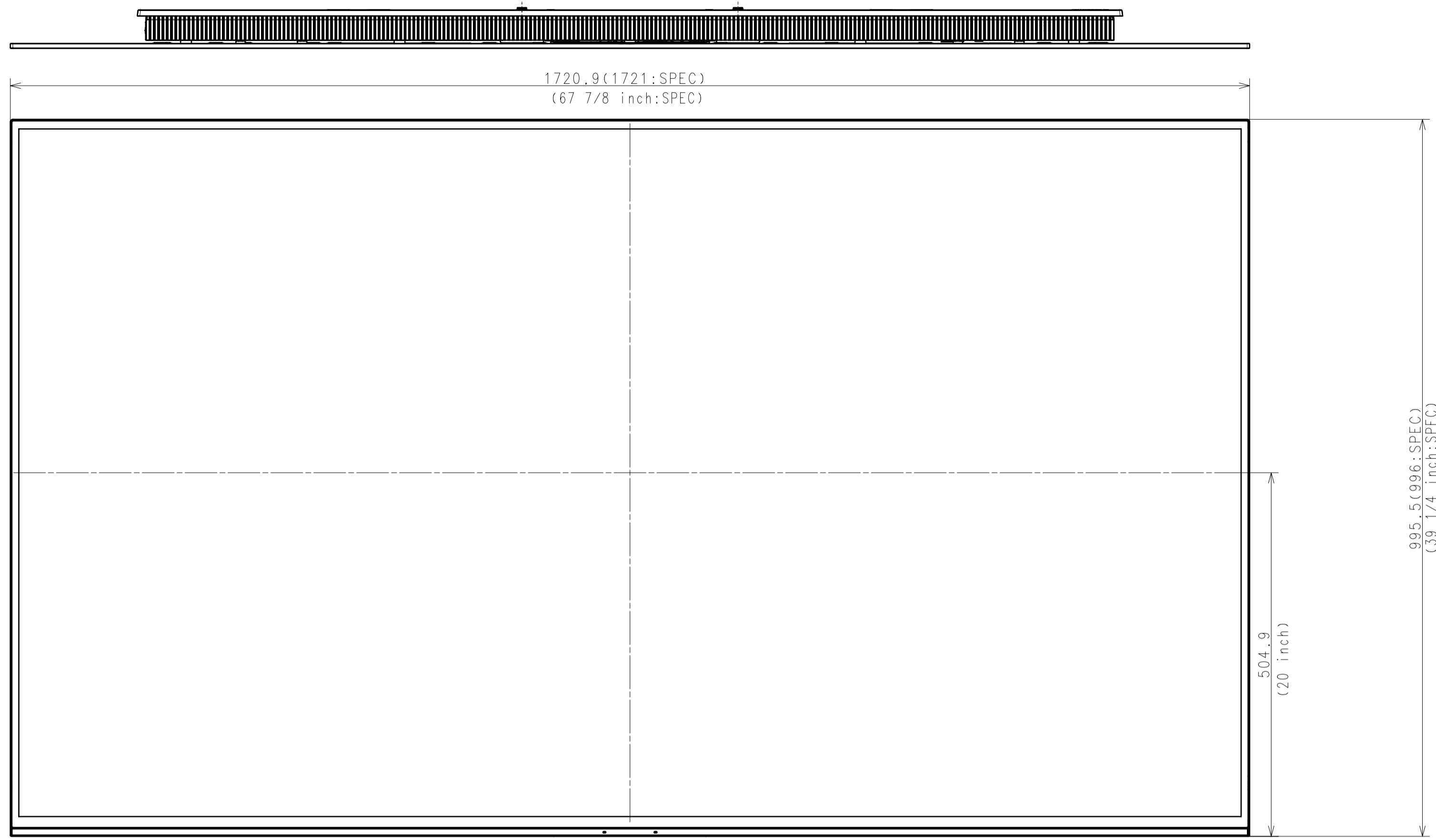

6.9(6.9:SPEC)  
(9/32 inch:SPEC)

53.4(49:SPEC)  
(1 15/16 inch:SPEC)

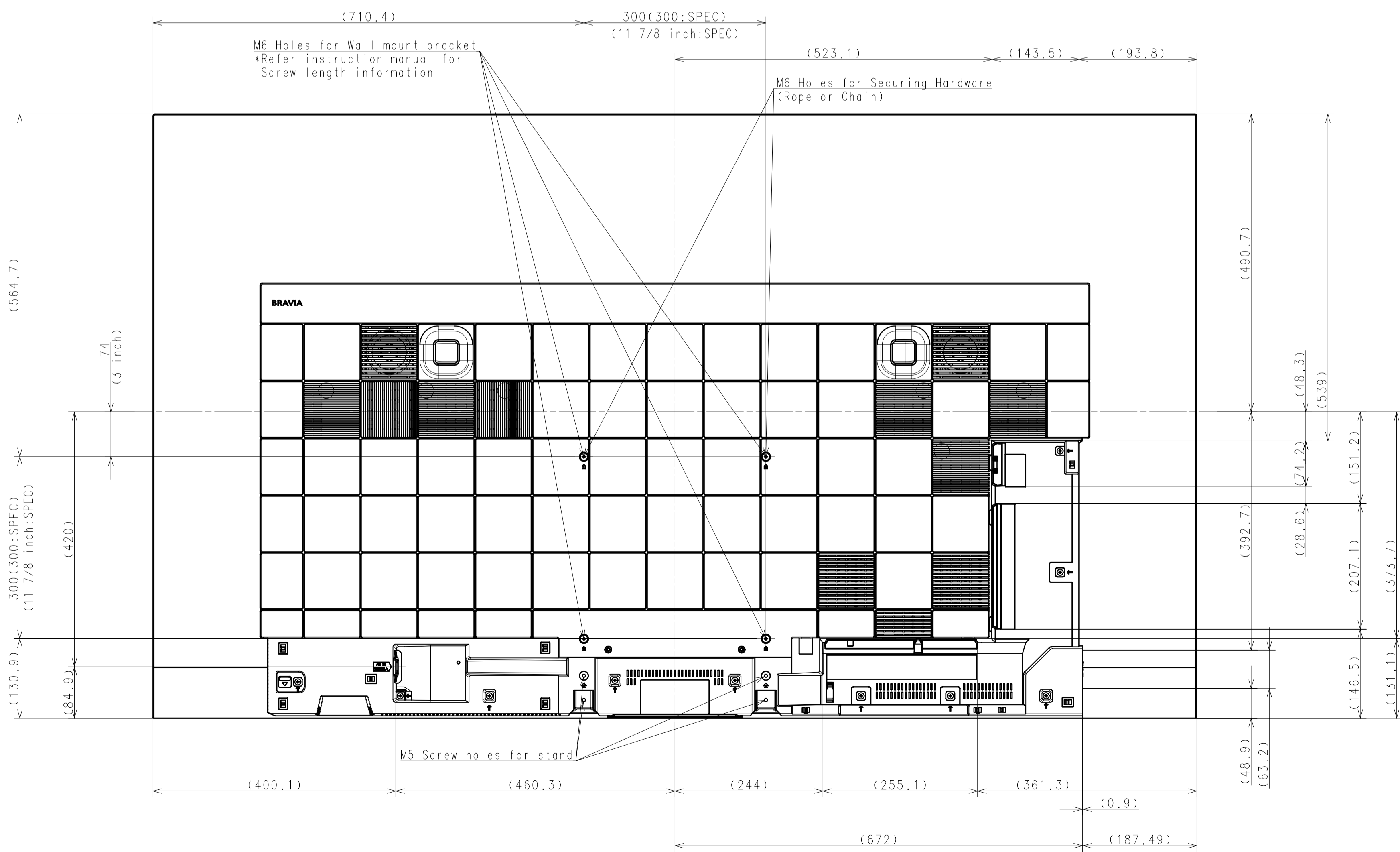
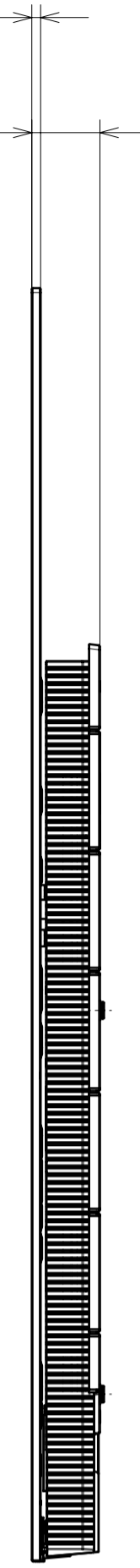

DESCRIPTION	LEGAL OWNER	SCALE
77 (A9G) EXTERIOR VIEW	Sony Corporation	1:5
DESCRIPTION	PART NO.	SHEET/PAGES
77 (A9G) EXTERIOR VIEW		2 / 5

SU-WL450 SLIM

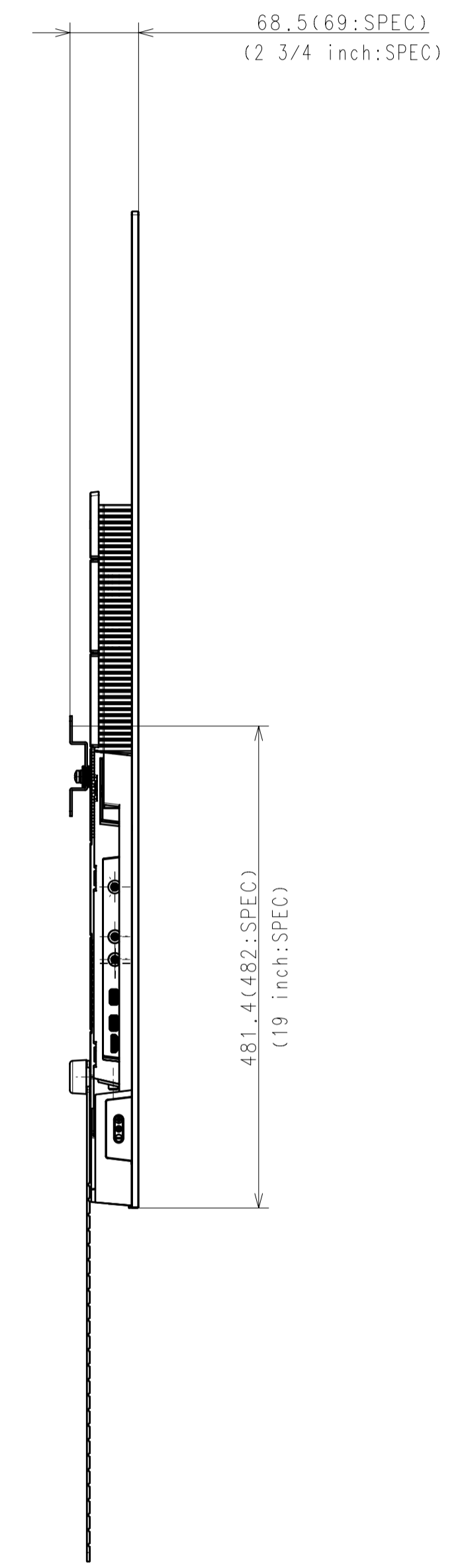
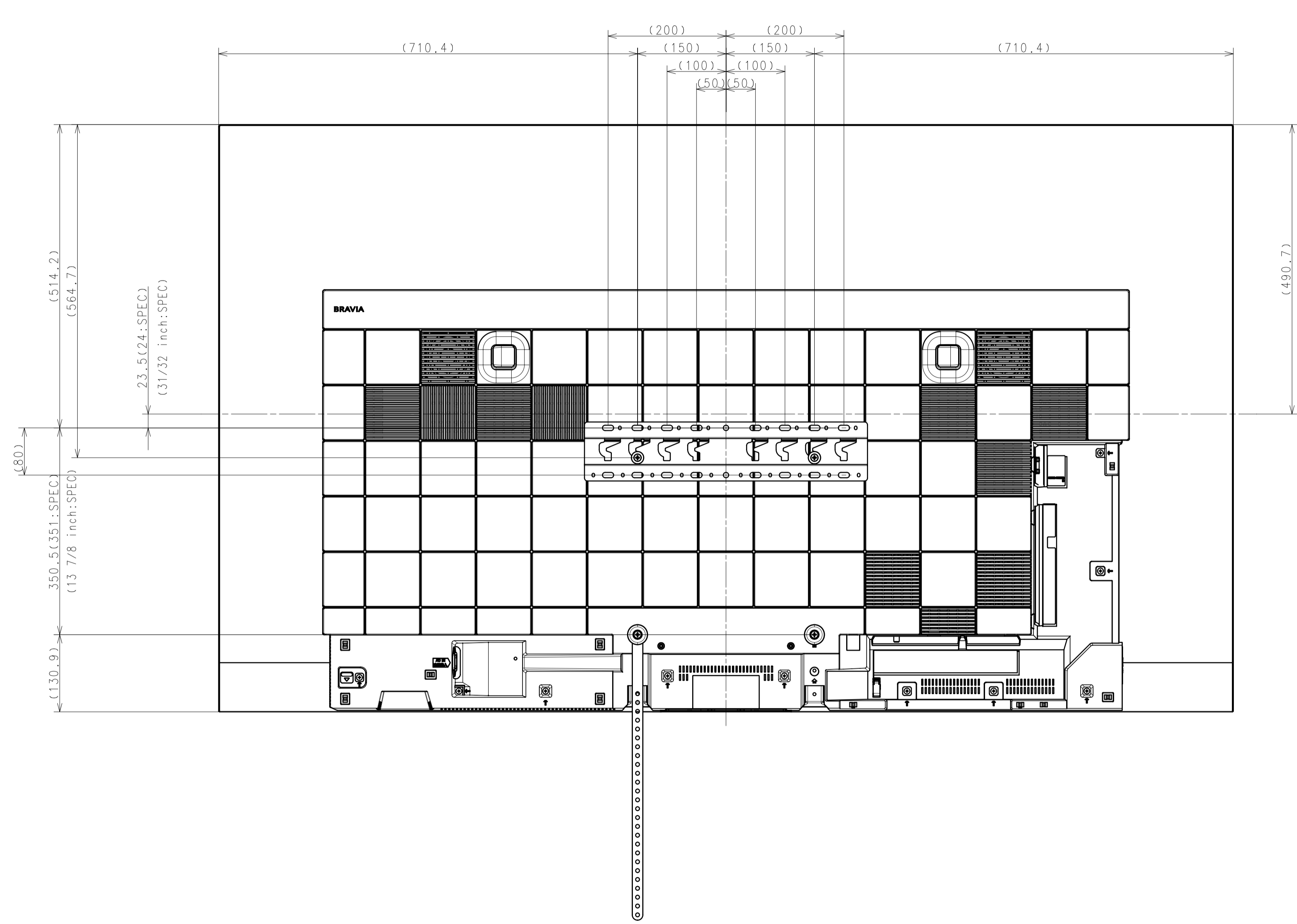

DESCRIPTION	LEGAL OWNER	SCALE
77 (A9G) EXTERIOR VIEW	Sony Corporation	1:5
DESCRIPTION	PART NO.	SHEET/PAGES
77 (A9G) EXTERIOR VIEW		3 / 5

SU-WL850

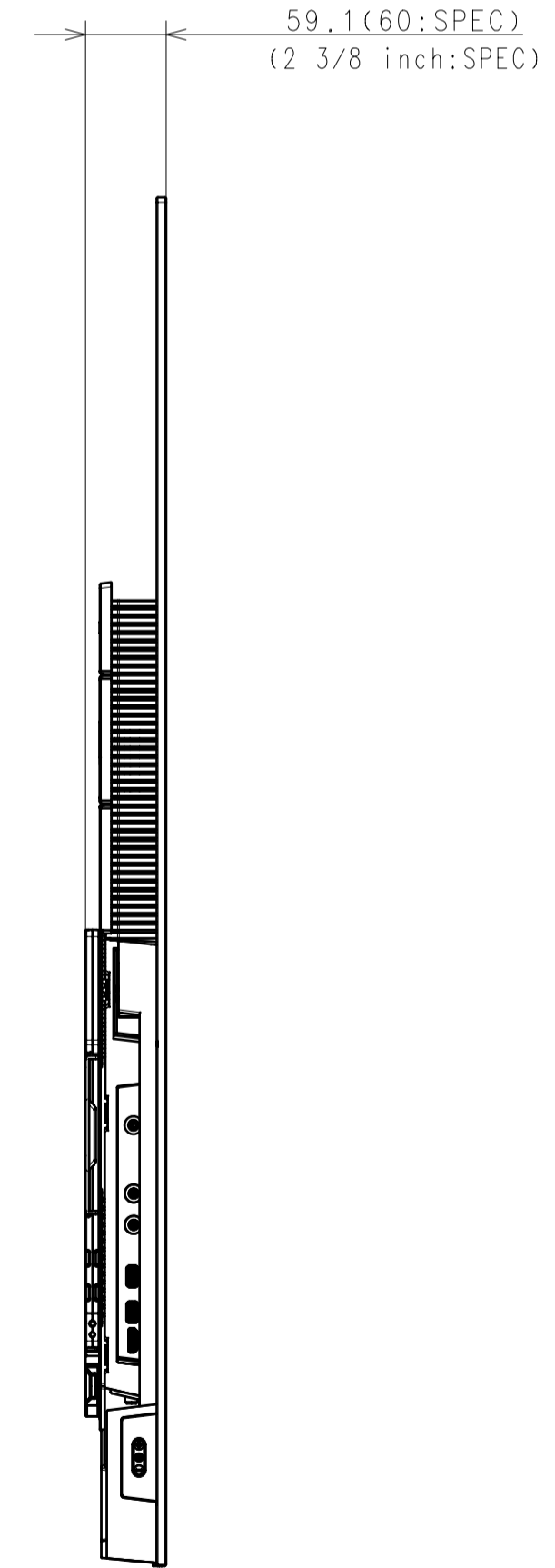
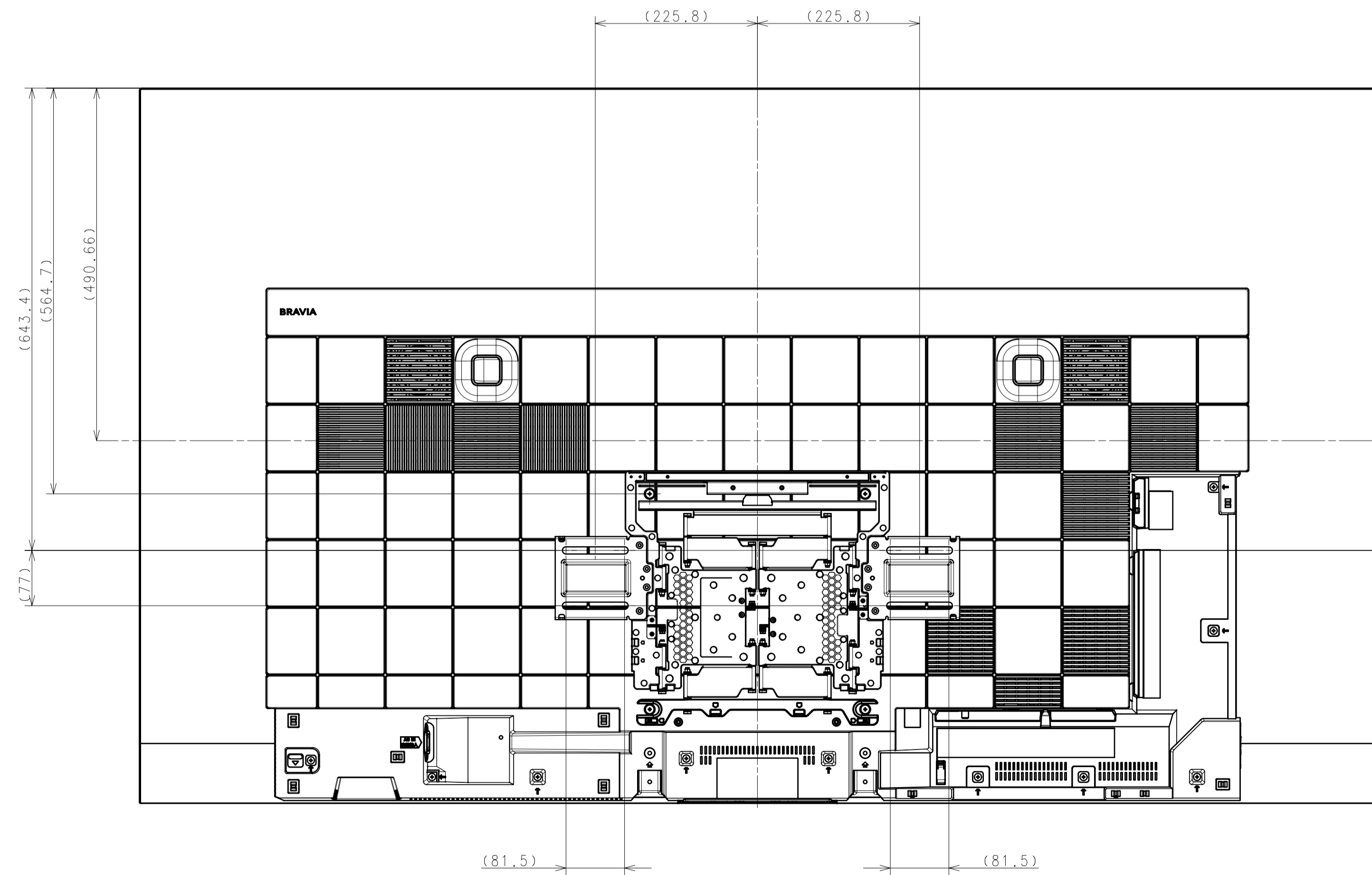
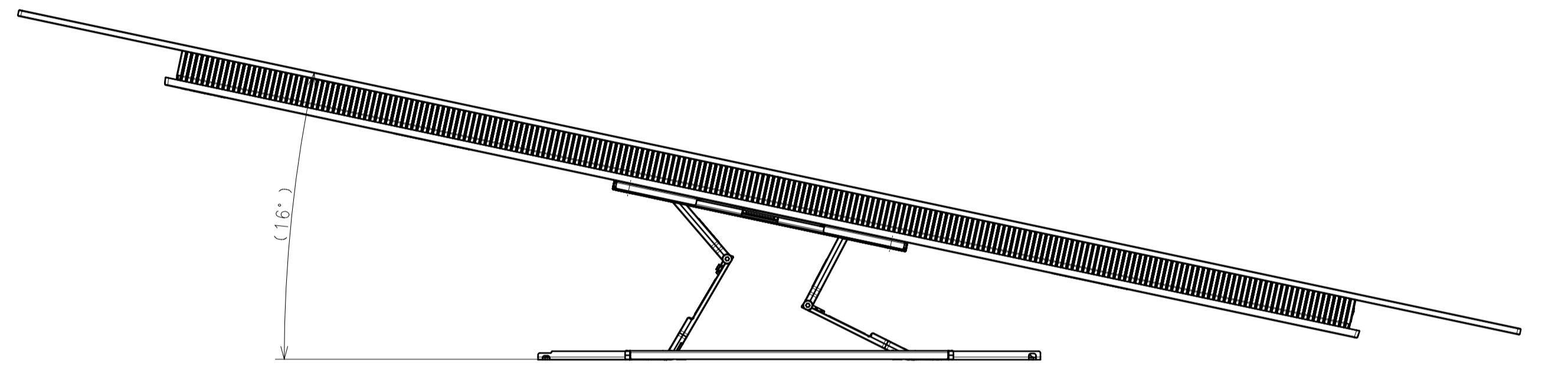
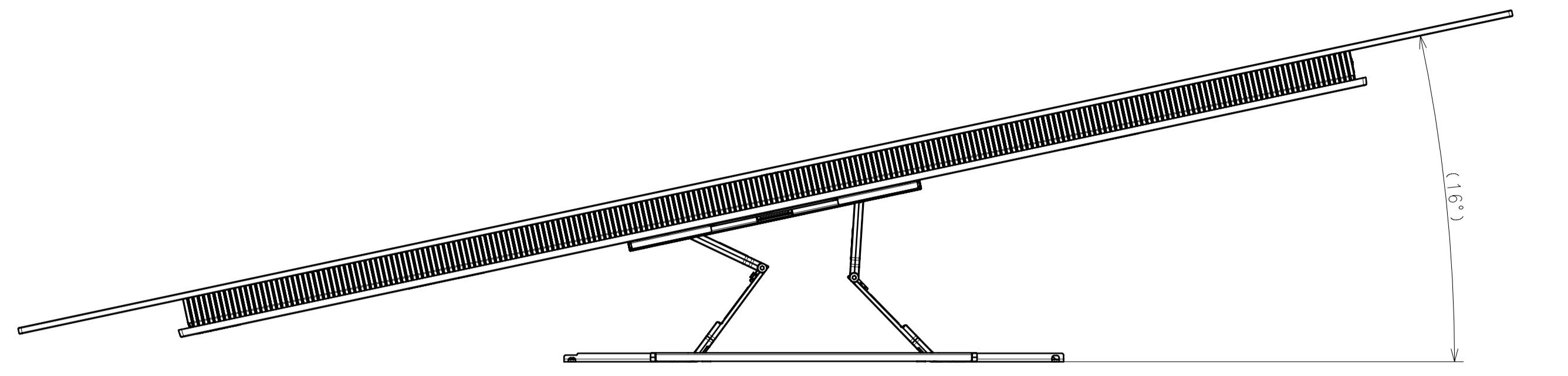
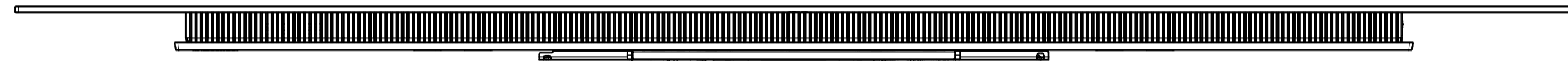
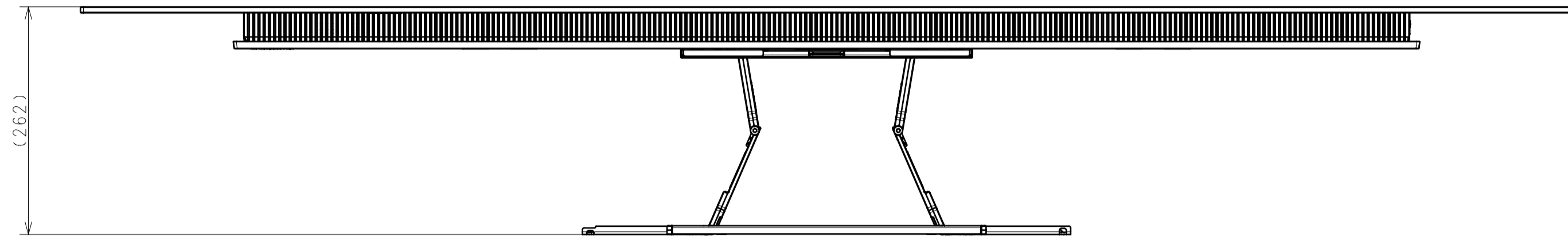

DESCRIPTION 1	LEGAL OWNER	SCALE
77 (A9G) EXTERIOR VIEW	Sony Corporation	1:5
DESCRIPTION 2	PART NO.	SHEET/PAGES
77 (A9G) EXTERIOR VIEW		4 / 5

# SU-WL855 WITH LATERAL SHAFT BRACKET

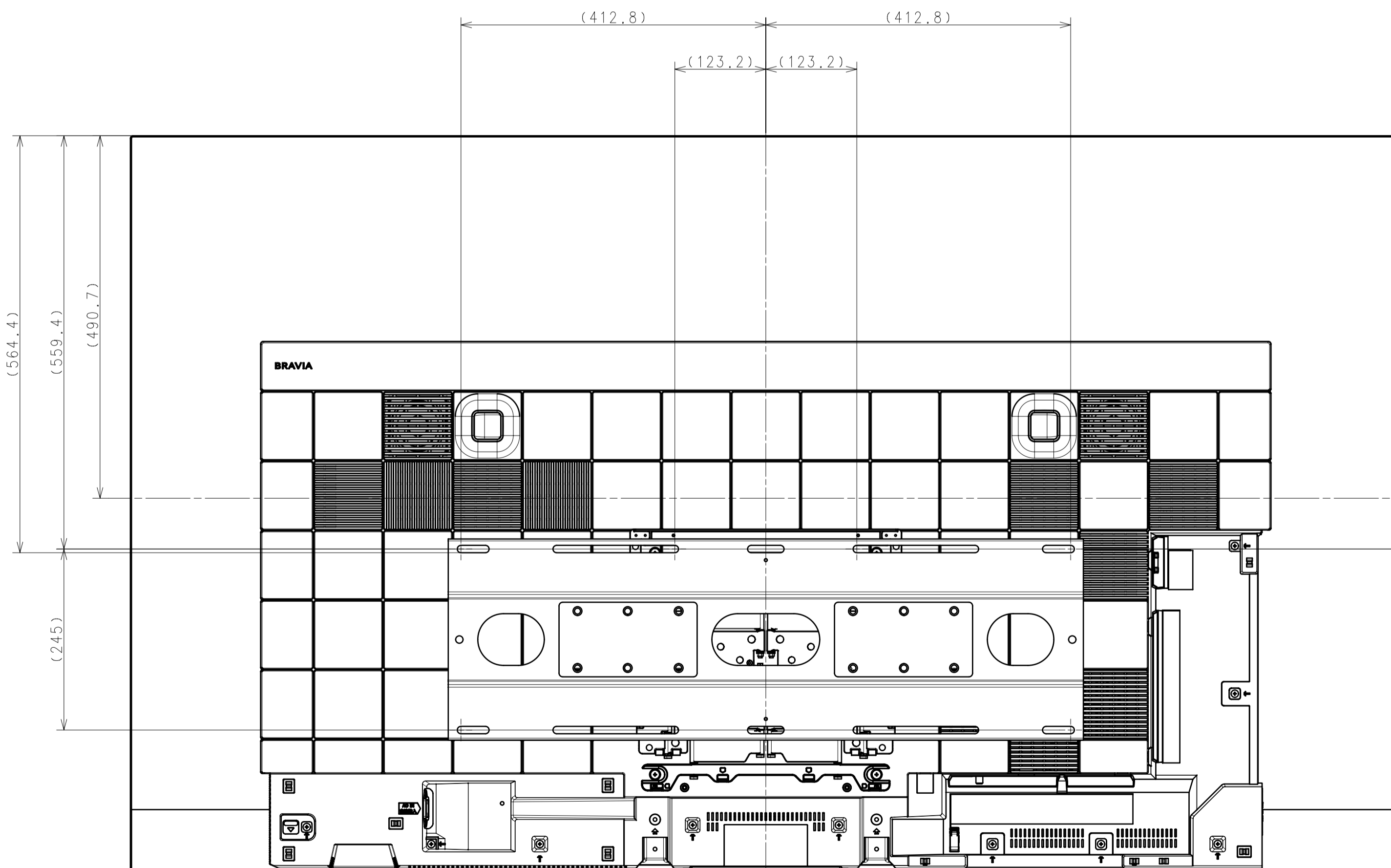
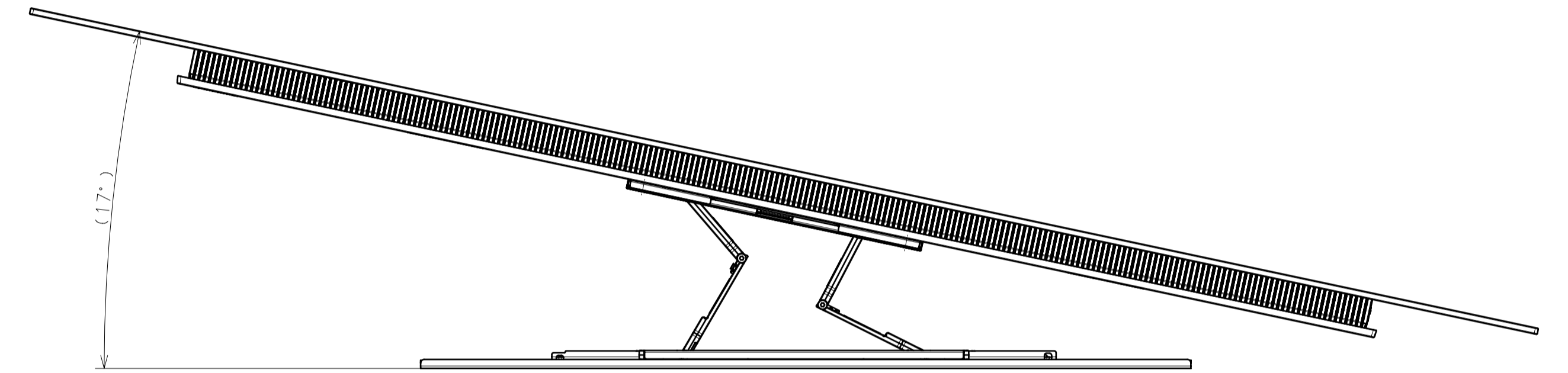
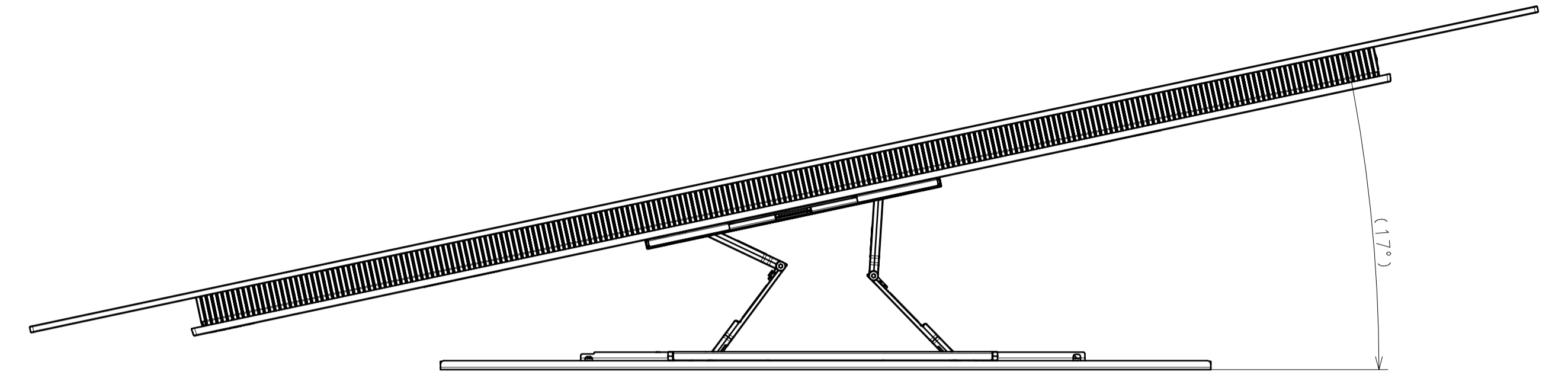
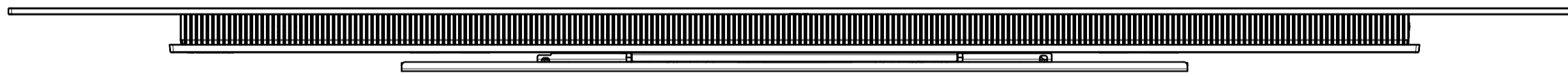
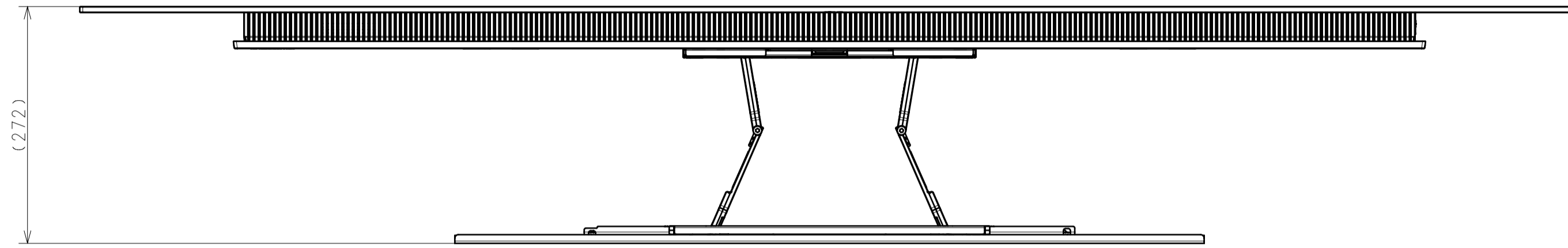

69.6 (71:SPEC)  
(2 7/8 inch:SPEC)

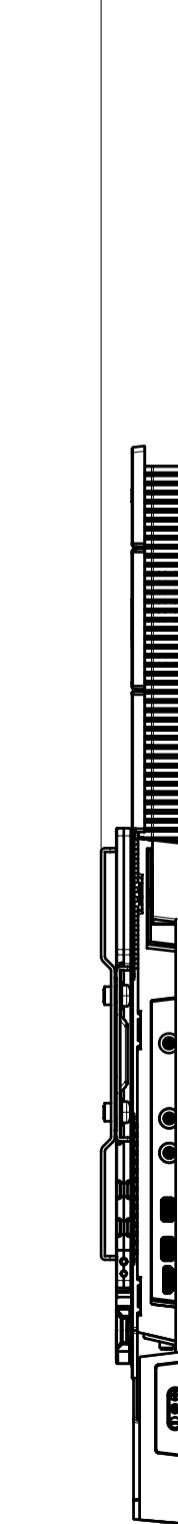

DESCRIPTION 1	LEGAL OWNER	SCALE
77 (A9G) EXTERIOR VIEW	Sony Corporation	1:5
DESCRIPTION 2	PART NO.	SHEET/PAGES
77 (A9G) EXTERIOR VIEW		5 / 5