

Area	JAPAN	NORTH AMERICA	LATIN AMERICA	EUROPE	GENERAL AREA	CHINA	
Model Name	XRJ-65A80J	XR-65A80J	XR-65A80J	XR-65A80J	XR-65A80J	XR-65A80J	
SV No.	SV-39373	SV-39180	SV-39198	SV-39343	SV-39228	SV-39306	
DIMENSION	TV only (W x H x D)	144.8 x 83.6 x 5.3 (0.63) cm	1448 x 836 x 53 (6.3) mm / 57 1/8 x 33 x 2 1/8 (1/4) inch	1448 x 836 x 53 (6.3) mm	Approx. 144.8 x 83.6 x 5.3 (0.63) cm	Approx. 1448 x 836 x 53 (6.3) mm	Approx. 1448 x 836 x 53 (6.3) mm
	TV with Stand (Standard position) (W x H x D)	144.8 x 85.9 x 33.0 cm	1448 x 859 x 330 mm / 57 1/8 x 33 7/8 x 13 inch	1448 x 859 x 330 mm	Approx. 144.8 x 85.9 x 33.0 cm	Approx. 1448 x 859 x 330 mm	Approx. 1448 x 859 x 330 mm
	TV with Stand (Narrow position) (W x H x D)	144.8 x 85.9 x 33.0 cm	1448 x 859 x 330 mm / 57 1/8 x 33 7/8 x 13 inch	1448 x 859 x 330 mm	Approx. 144.8 x 85.9 x 33.0 cm	Approx. 1448 x 859 x 330 mm	Approx. 1448 x 859 x 330 mm
	TV with Stand (Soundbar position) (W x H x D)	144.8 x 90.8 x 33.0 cm	1448 x 908 x 330 mm / 57 1/8 x 35 3/4 x 13 inch	1448 x 908 x 330 mm	Approx. 144.8 x 90.8 x 33.0 cm	Approx. 1448 x 908 x 330 mm	Approx. 1448 x 908 x 330 mm
	TV with Floor Stand (W x H x D)	-	-	-	-	-	-
	Stand Width (Standard position)	-	-	-	-	-	-
	Stand Width (Narrow position)	-	-	-	-	-	-
	Stand Width (Soundbar position)	-	-	-	-	-	-
	Floor Stand Width	-	-	-	-	-	-
VESA Hole Pitch	30.0 x 30.0 cm	300 x 300 mm / 11 7/8 x 11 7/8 inch	300 x 300 mm	30.0 x 30.0 cm	300 x 300 mm	300 x 300 mm	
WEIGHT	TV Only	22.3 kg	22.3 kg / 49.2 lb	22.3 kg	Approx. 22.3 kg	Approx. 22.3 kg	Approx. 22.3 kg
	TV with Stand (Standard position)	23.5 kg	23.5 kg / 51.8 lb	23.5 kg	Approx. 23.5 kg	Approx. 23.5 kg	Approx. 23.5 kg
	TV with Stand (Narrow position)	23.5 kg	23.5 kg / 51.8 lb	23.5 kg	Approx. 23.5 kg	Approx. 23.5 kg	Approx. 23.5 kg
	TV with Stand (Soundbar position)	23.5 kg	23.5 kg / 51.8 lb	23.5 kg	Approx. 23.5 kg	Approx. 23.5 kg	Approx. 23.5 kg
	TV with Floor Stand	-	-	-	-	-	-
	Floor Stand weight (Supply)	-	-	-	-	-	-
W-M't Br. Weight (Supply)	-	-	-	-	-	-	
Remarks	3way	3way	3way	3way	3way	3way	

WITH STAND
STANDARD POSITION

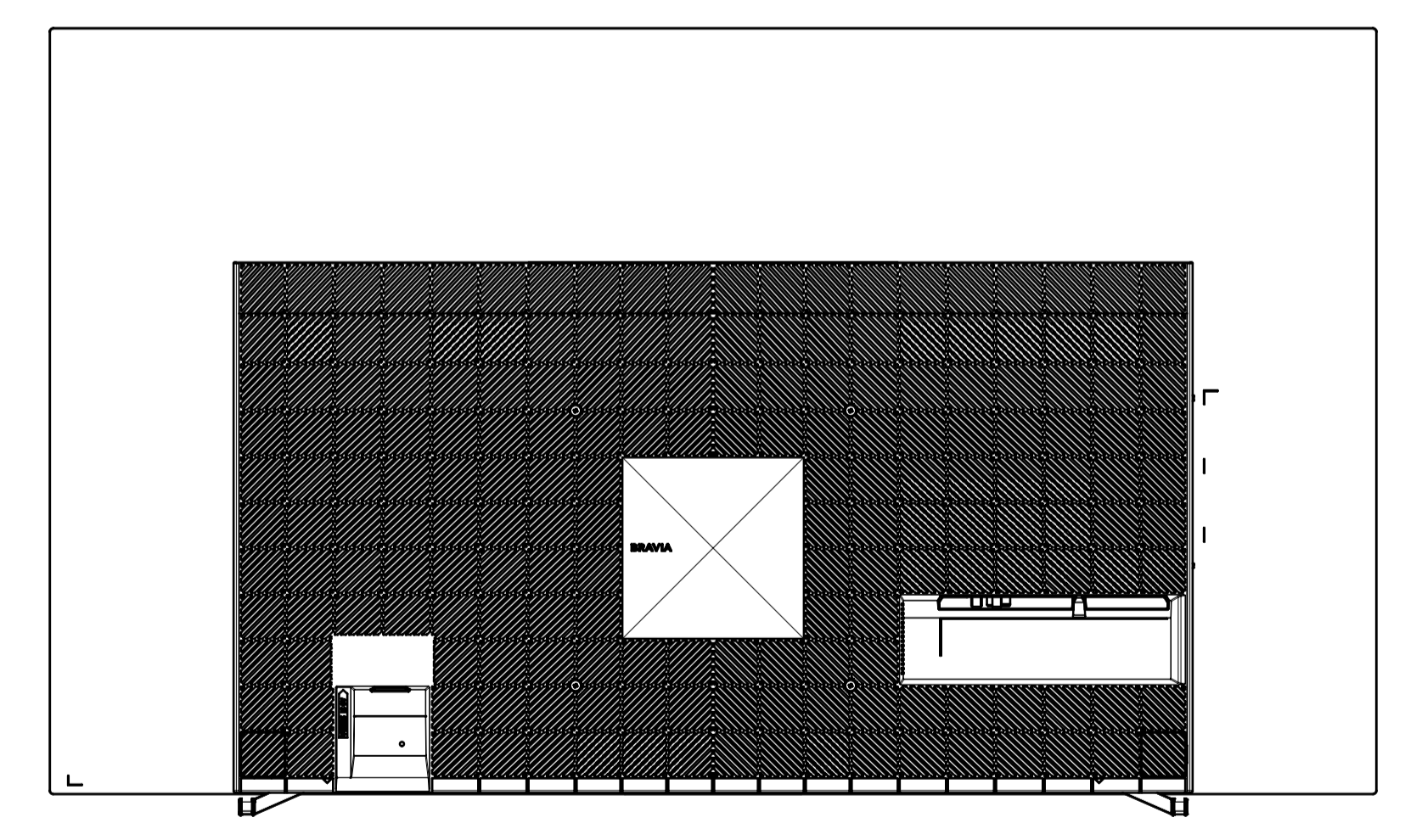
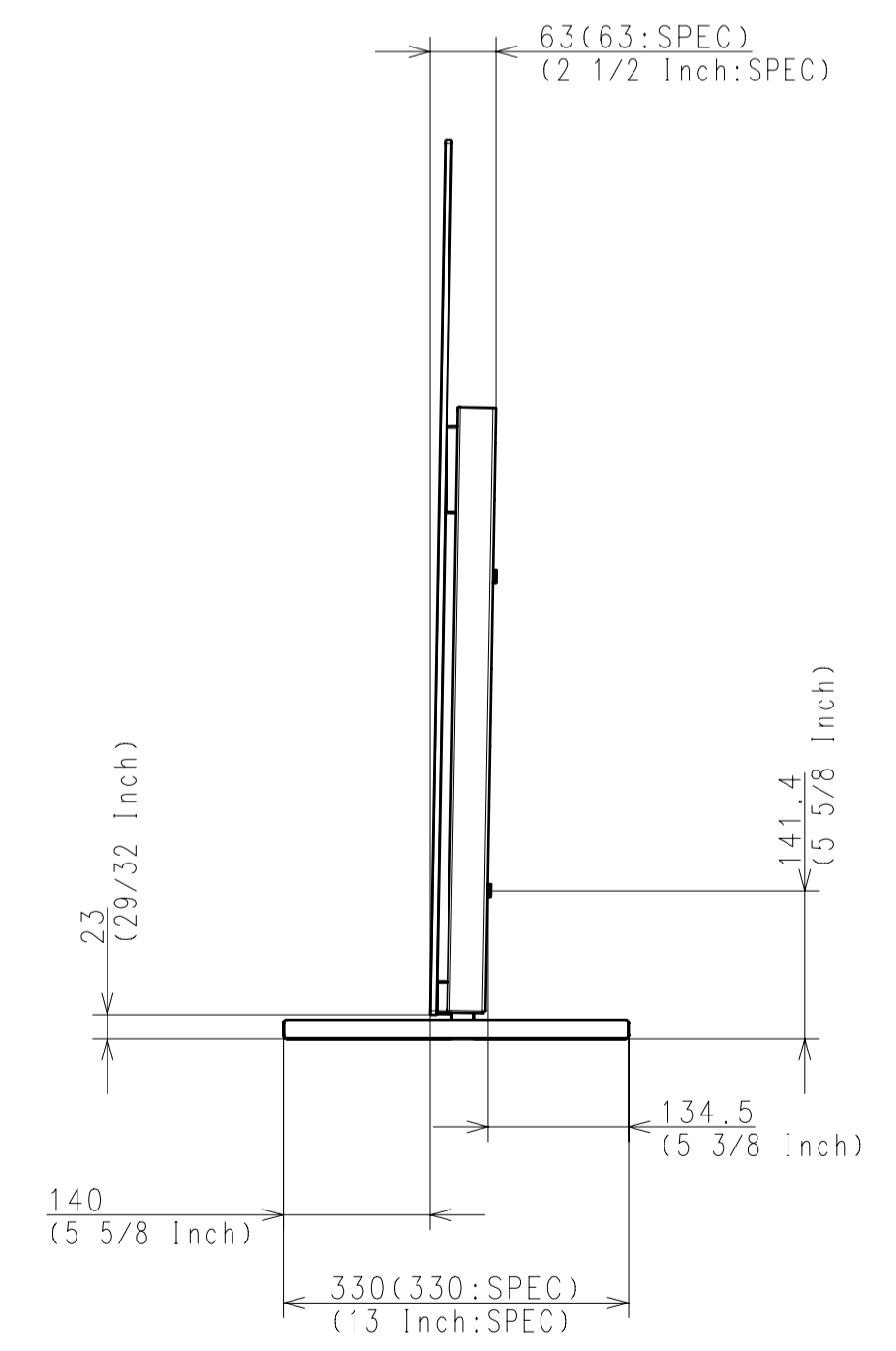
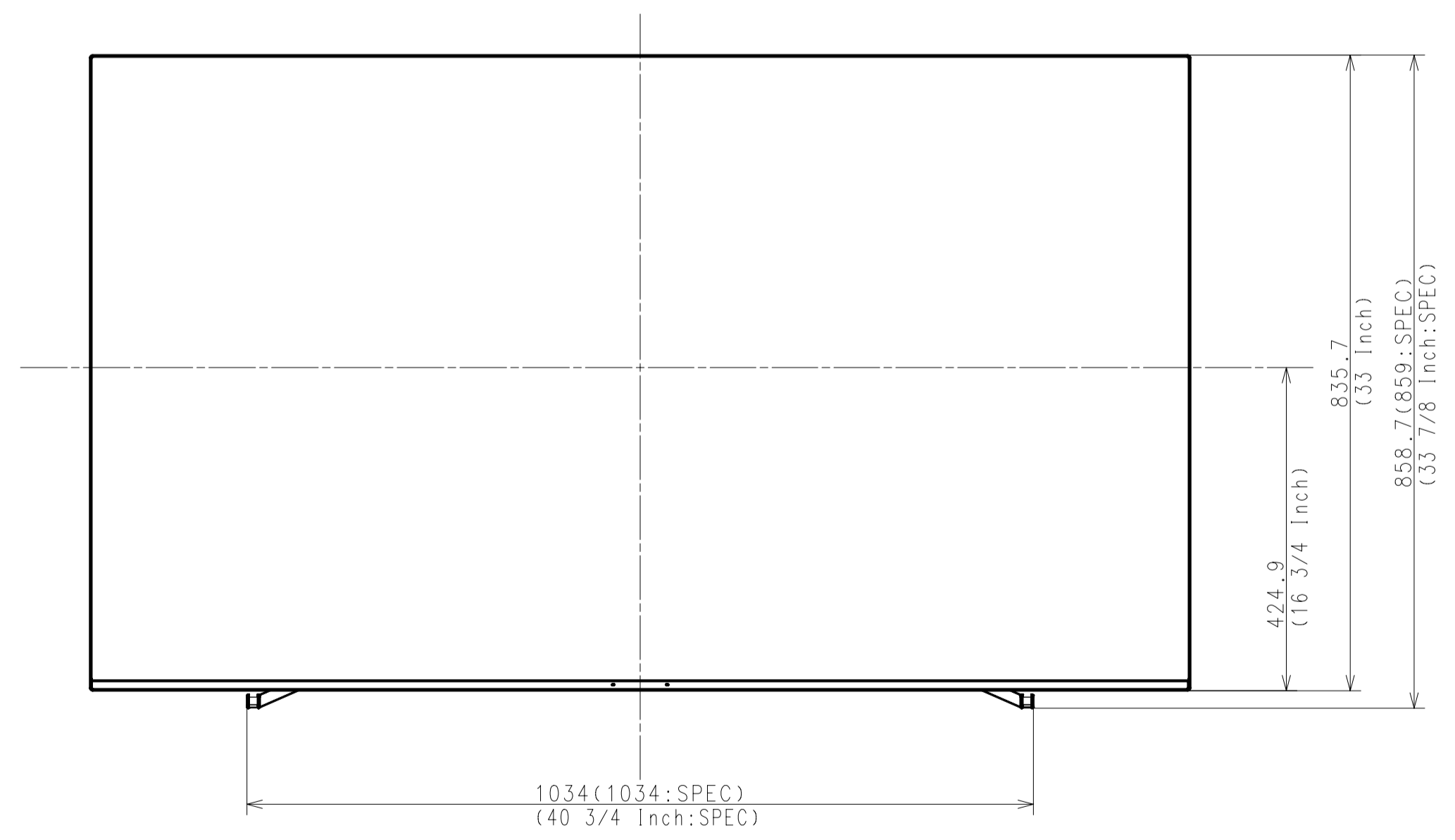
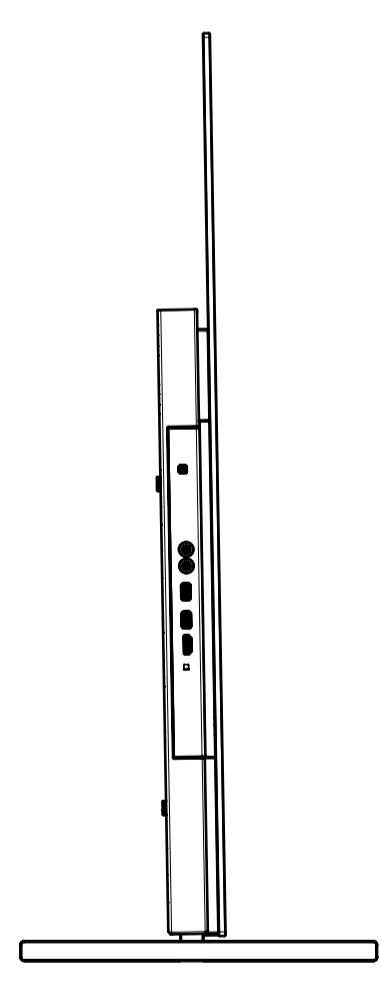
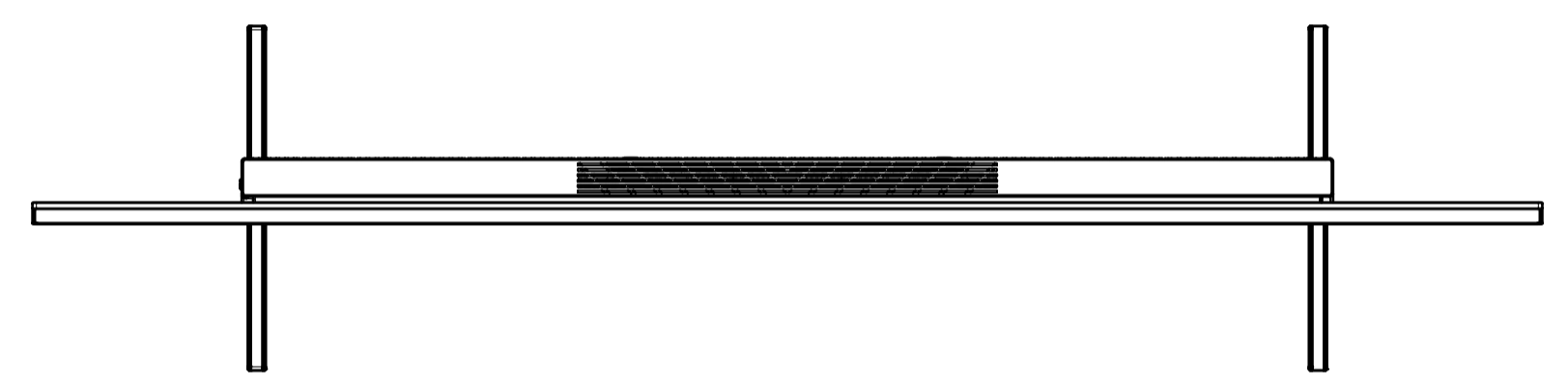

Purchase recycled resins and wire rods only from the business partners that Sony approves as Green Partners.
再生樹脂・銅線材はグリーンパートナー 認定製品から調達ください。

△A	△B	△C	△D	△E	△F	△G	△H	△I	△J	△K	△L
RESPONSIBLE DEPARTMENT: SHES TV Div. PLANNED BY: Kozuka, Amari DRAWN BY: Kozuka, Amari										GENERAL TOLERANCE DATE OF ISSUE: 2020.10.20 DOCUMENT TYPE: PART TOLERANCING DRAWING (JIS & ISO/IEC JIS)	
HISTORY & COUNT: 1 SUFFIX: - RELEASE NO.: - DATE: - REVISION: - SIGN: - LEGAL OWNER: Sony Corporation										MATERIAL COLOR: - FINISH COLOR: -	
ORIGINAL MODEL: 65(A80J) DESCRIPTION: 65(A80J) EXTERIOR VIEW TENTATIVE MODEL: 65(A80J) EXTERIOR VIEW SCALE: 1:7 SIZE: A1 UNIT: mm SHEET/PAGES: 1/4										PART NO.: - SUFFIX: - REV. NO.: - SHEET/PAGES: 1/4	

WITH STAND
SOUND BAR POSITION

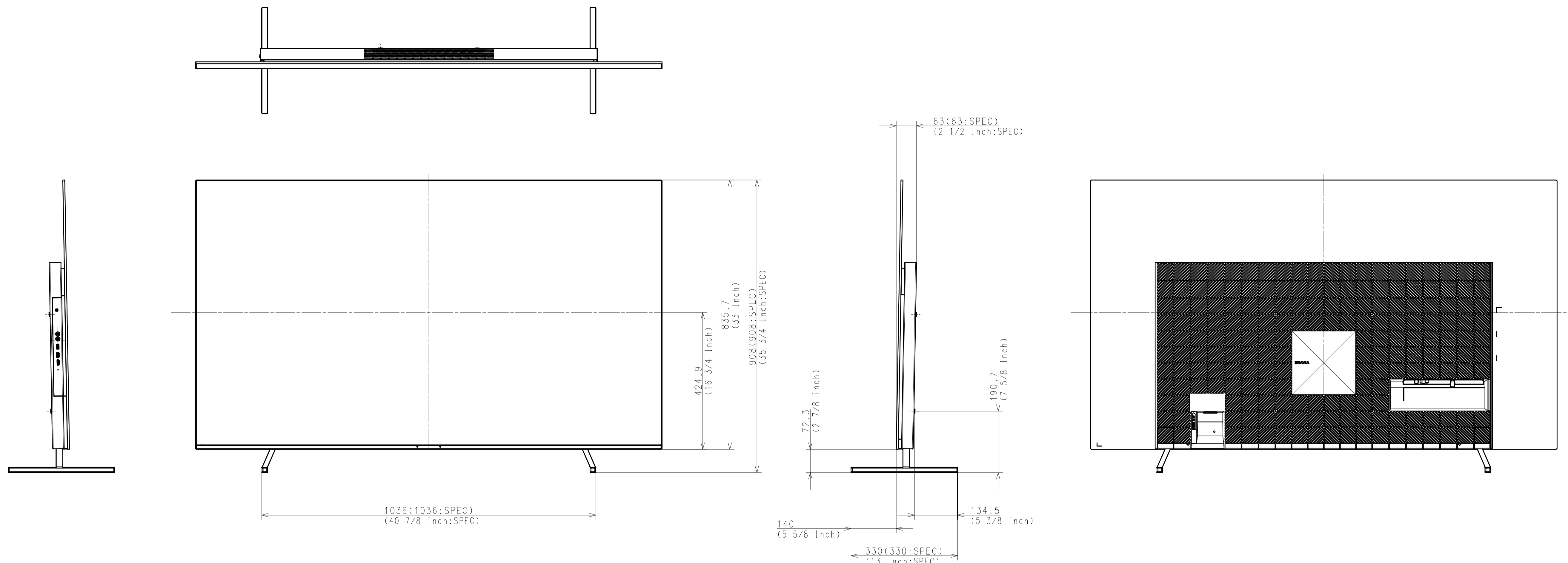

WITH STAND
NARROW POSITION

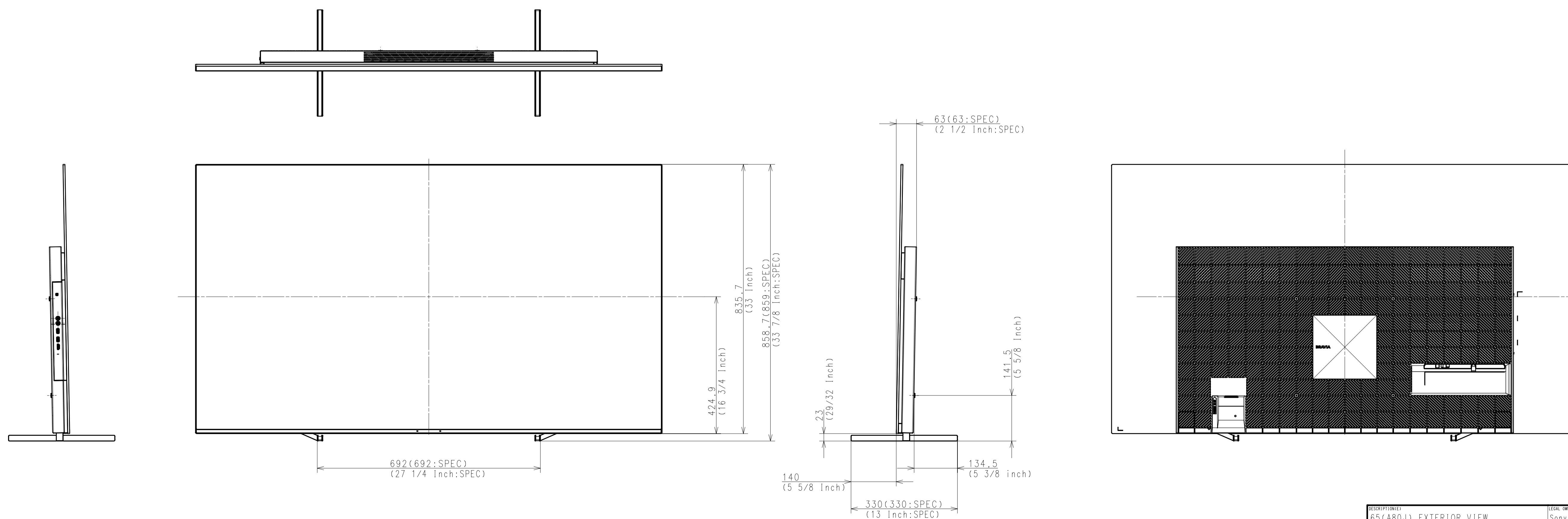

DESCRIPTION 1	LEGAL OWNER	SCALE
65(A80J) EXTERIOR VIEW	Sony Corporation	1:7
DESCRIPTION 2	PART NO.	SHEET/PAGES
65(A80J) EXTERIOR VIEW		2 / 4

WITHOUT STAND

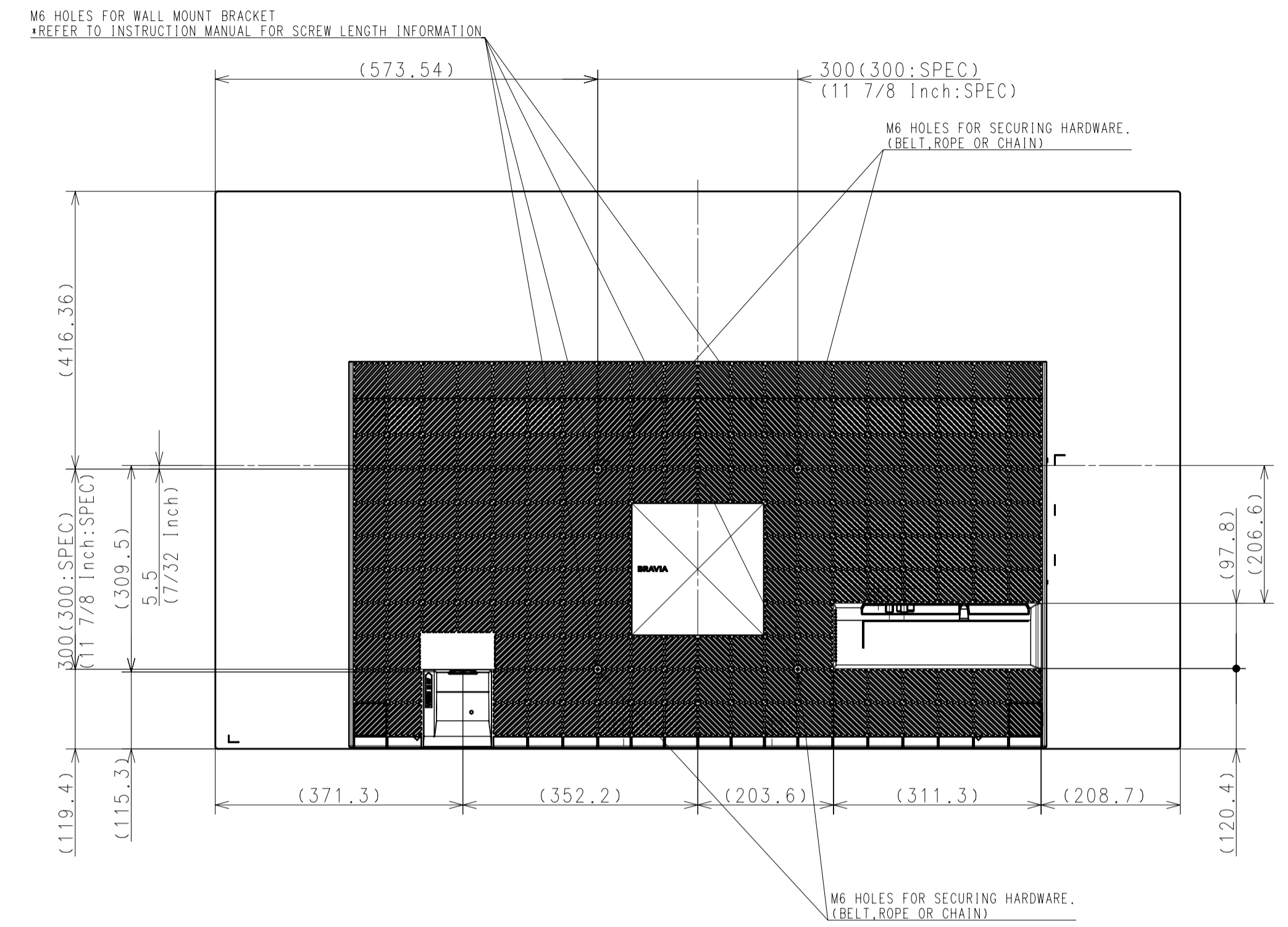
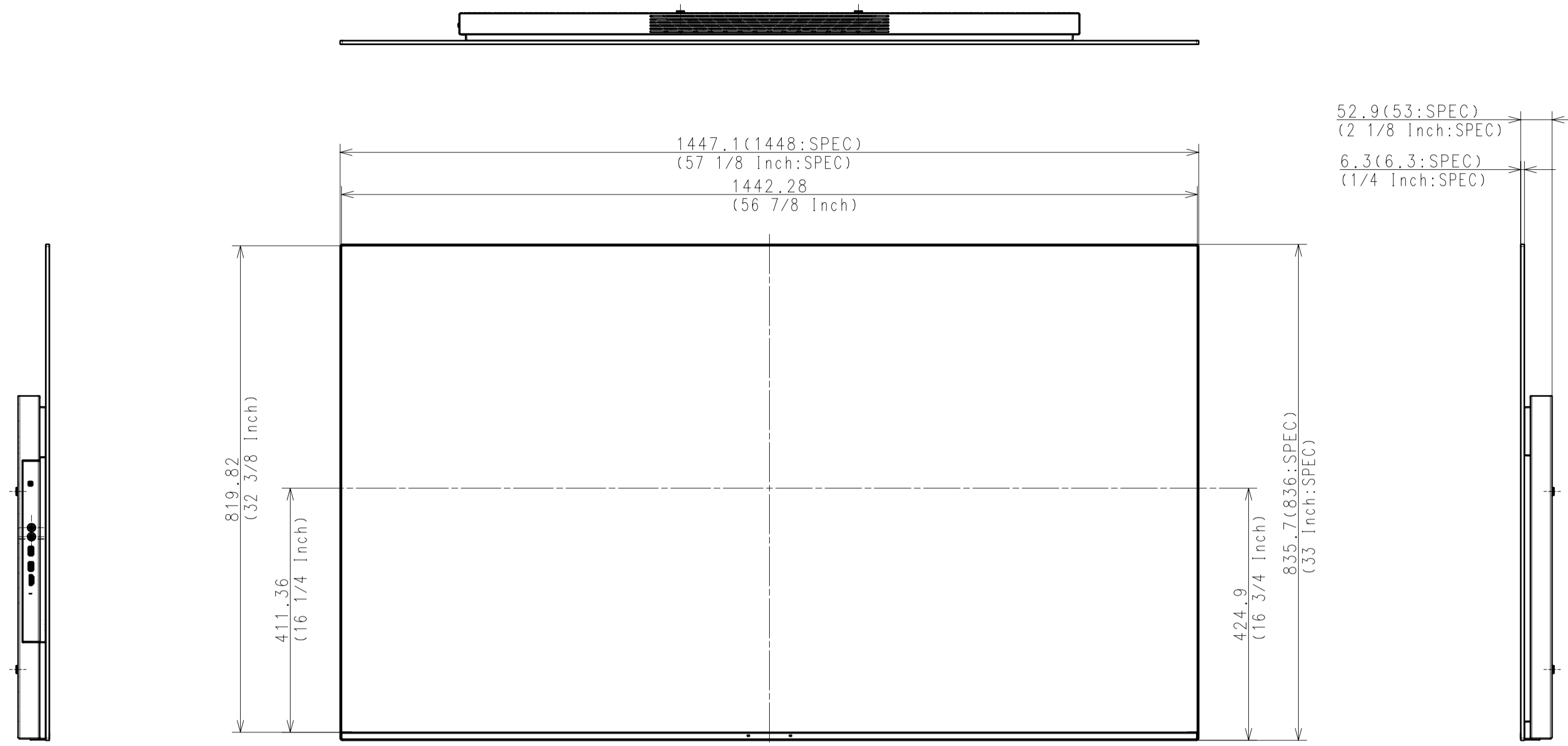

SU-WL450

STANDARD MOUNT

SLIM MOUNT

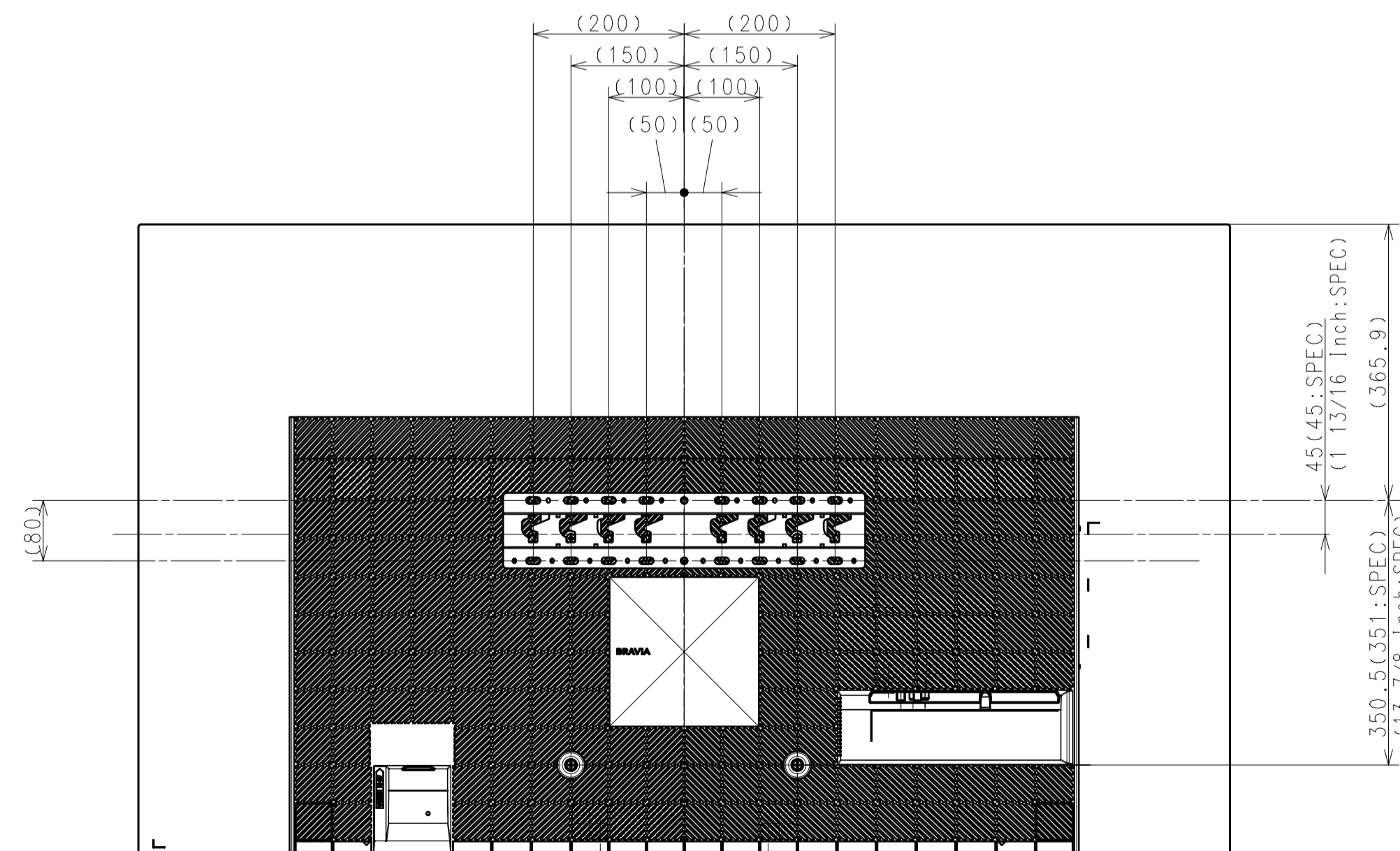

115 (115:SPEC) (4 5/8 Inch:SPEC)

73.2 (74:SPEC) (3 Inch:SPEC)

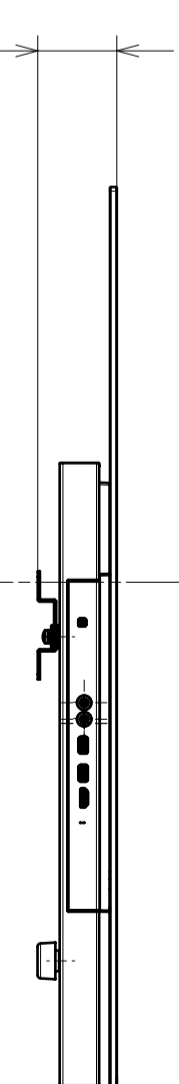
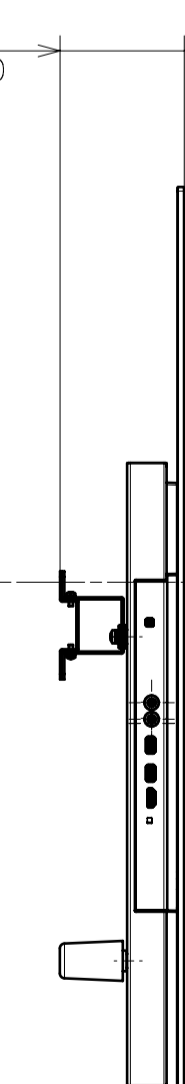

DESCRIPTION 1	LEGAL OWNER	SCALE
65(A80J) EXTERIOR VIEW	Sony Corporation	1:7
DESCRIPTION 2	PART NO.	SHEET/PAGES
65(A80J) EXTERIOR VIEW		3 / 4

SU-WL850

SU-WL855

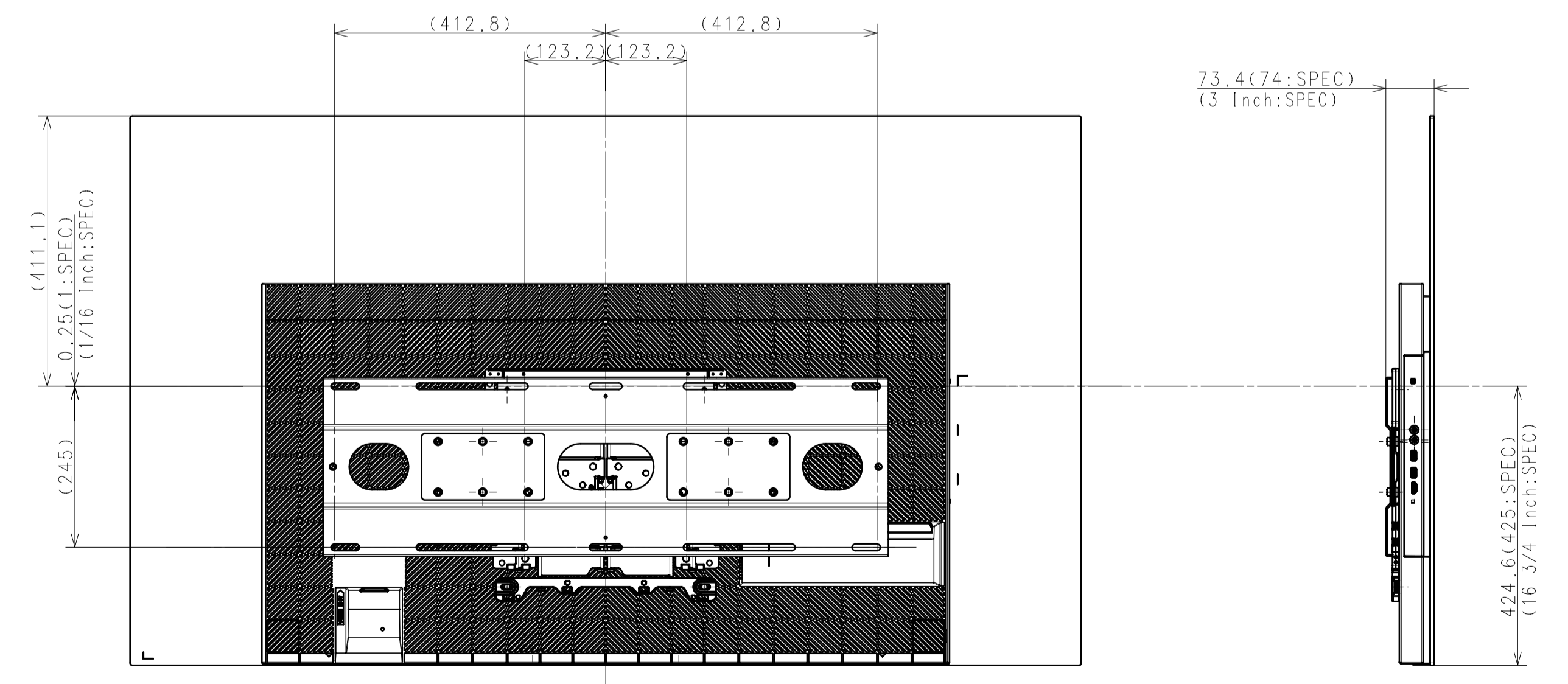
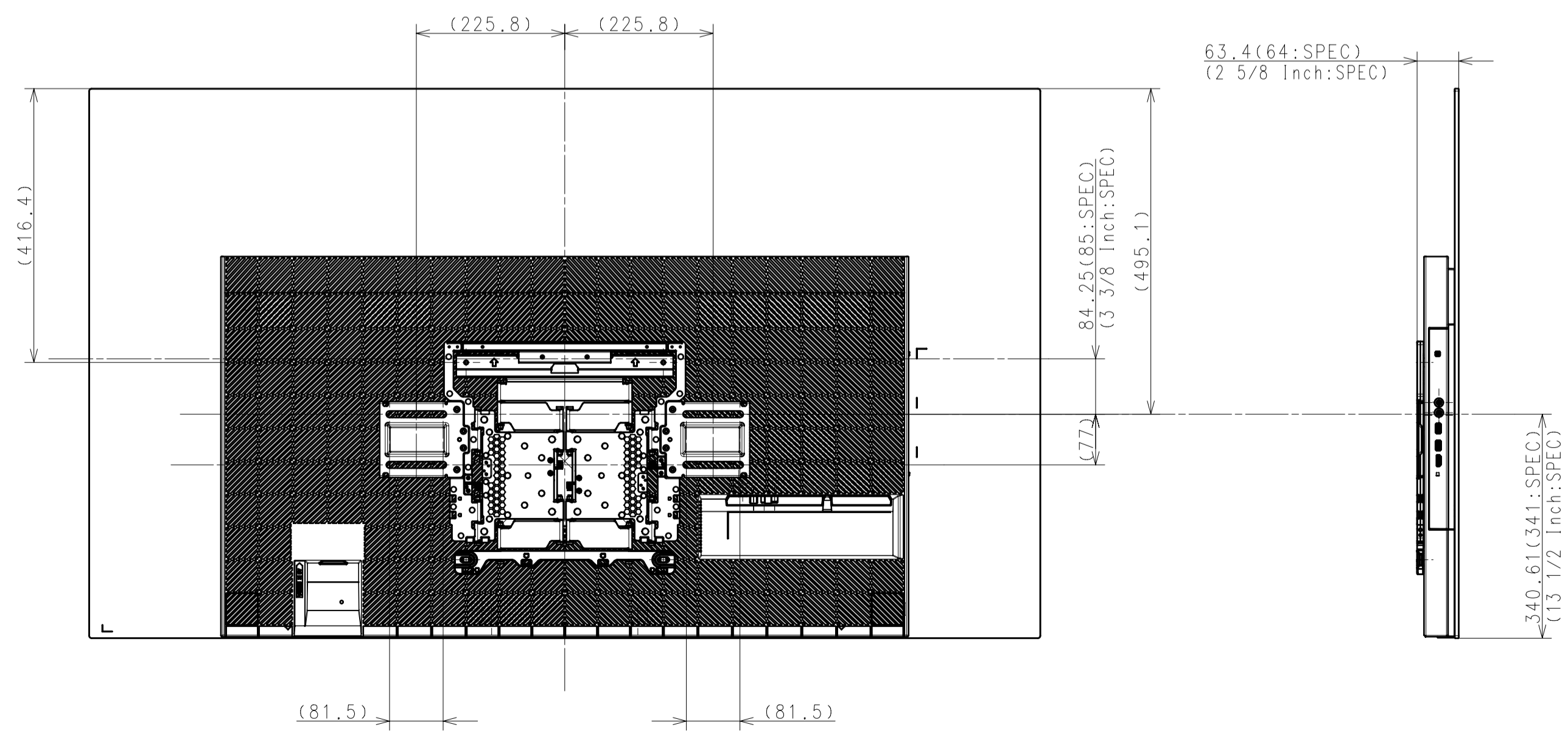
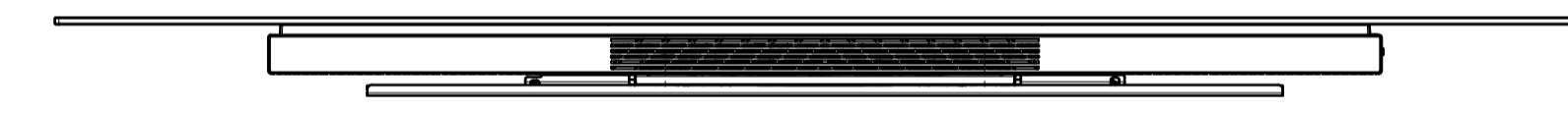
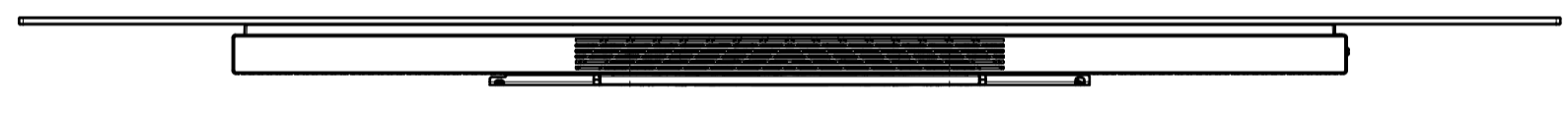
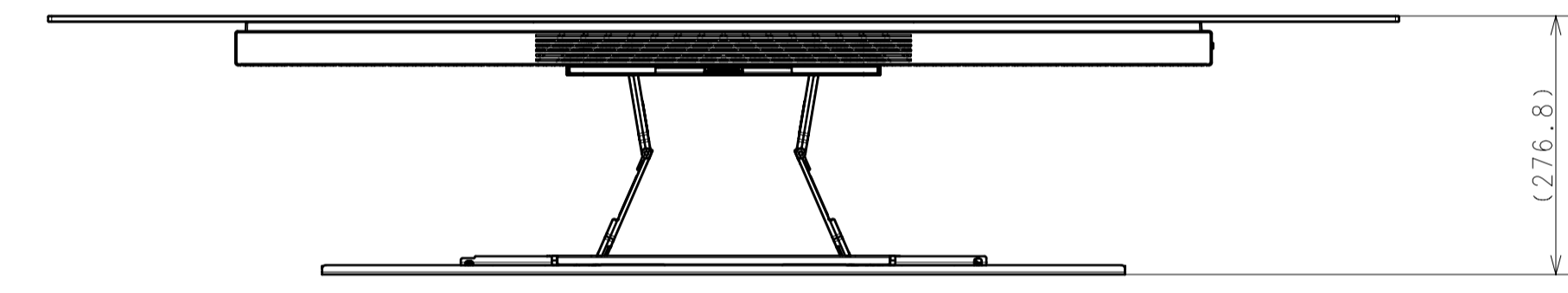
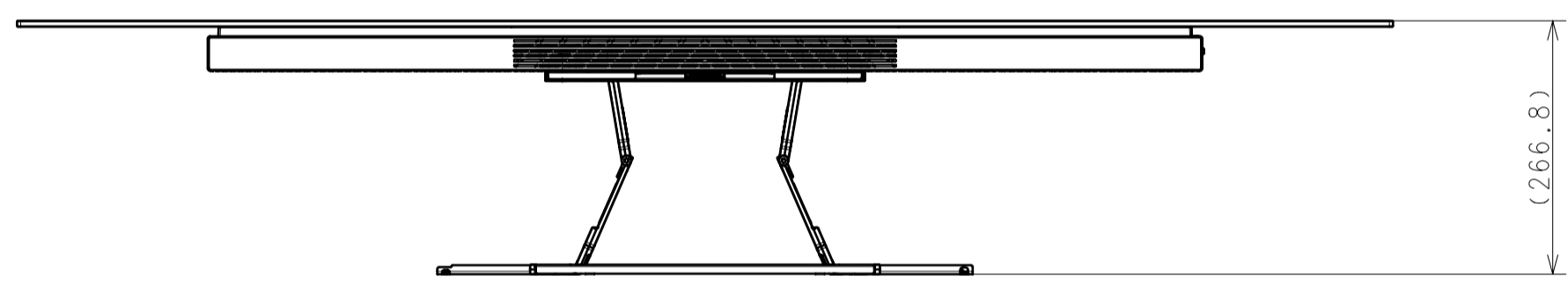
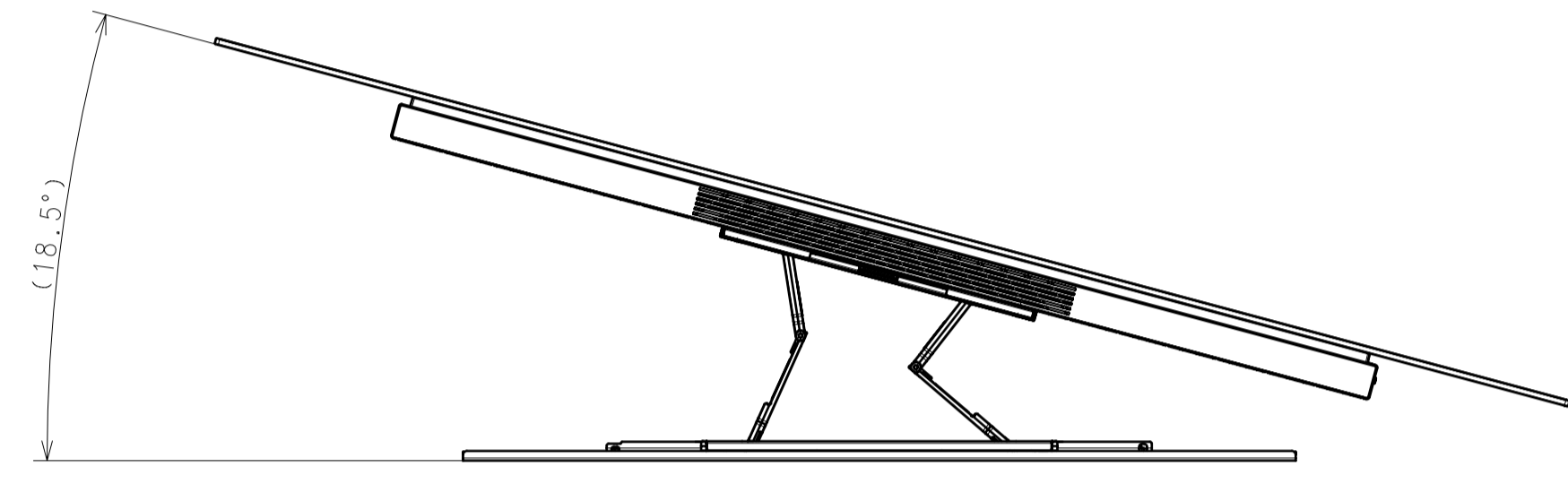
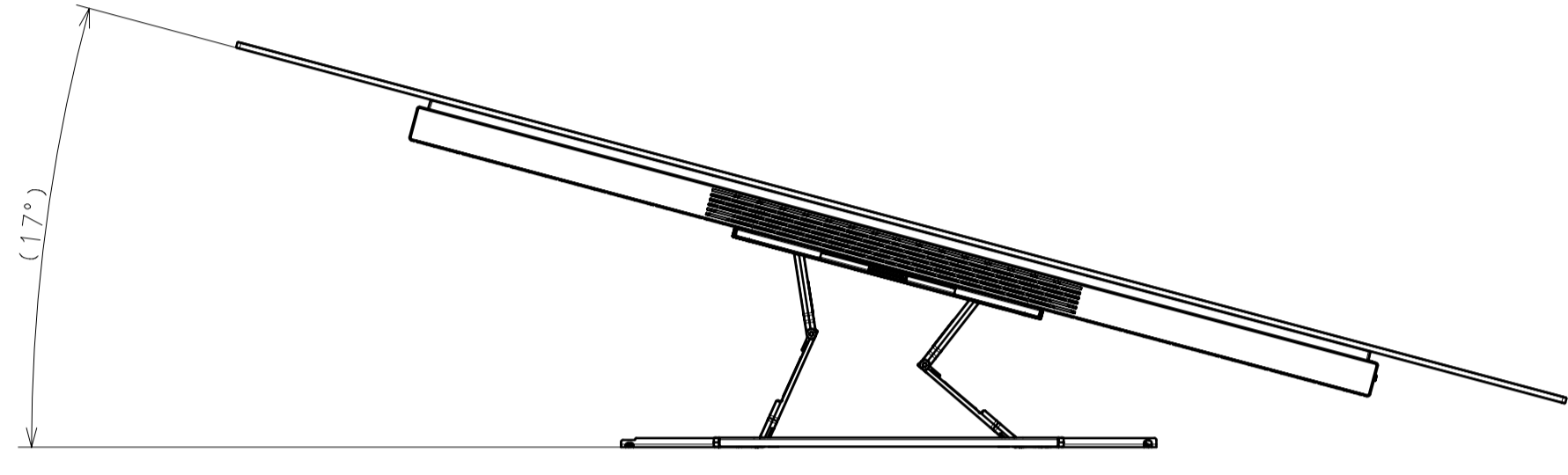
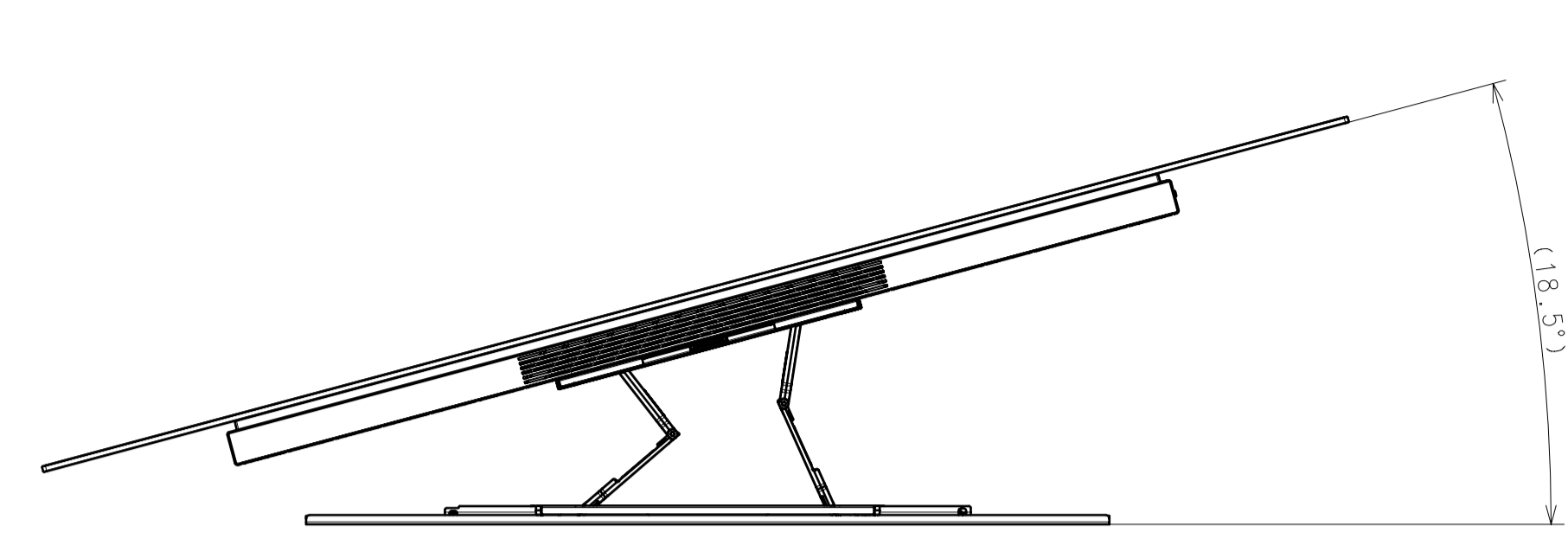
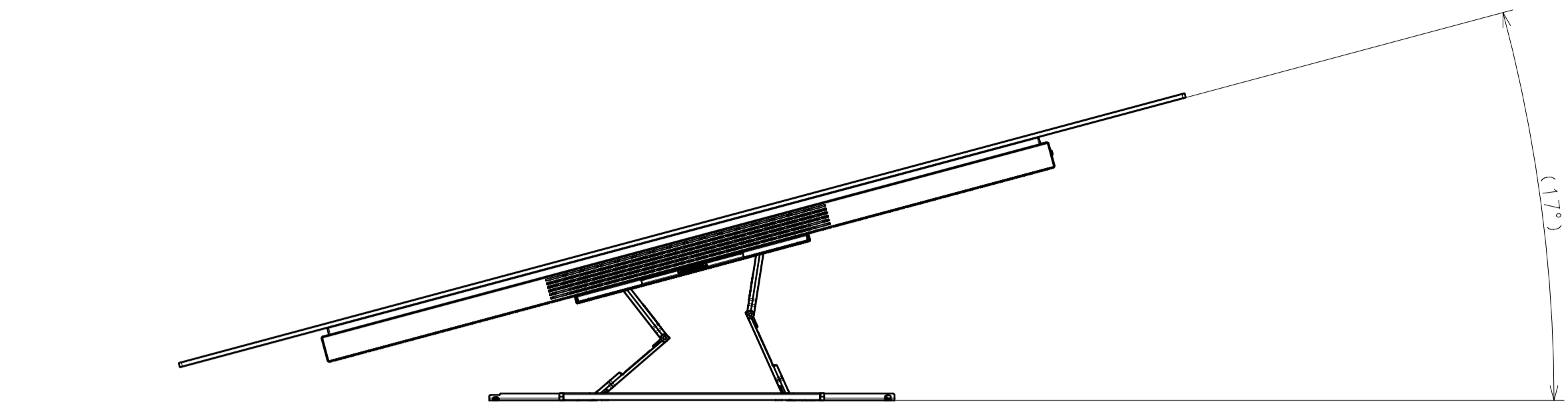

DESCRIPTION 1	LEGAL OWNER	SCALE
65(A80J) EXTERIOR VIEW	Sony Corporation	1:7
DESCRIPTION 2	PART NO.	SHEET/PAGES
65(A80J) EXTERIOR VIEW		4 / 4