

Area	JAPAN	NORTH AMERICA	LATIN AMERICA	EUROPE	EUROPE	GENERAL AREA	CHINA
Model Name	KJ-49X8000G	XBR-49X800G	XBR-49X800G	KD-49XG8096	KD-49XG8196	KD-49X8000G	KD-49X8000G
SV No.	SV-36211	SV-36374	SV-36160	SV-36206	SV-36382	SV-36185	SV-36201
DIMENSION	TV only (WxHxD)	110.1x64.5x5.7(1.30) cm	1101x645x57(13) mm / 43 3/8 x 25 1/2 x 2 1/4(17/32) inch	1101x645x57(13) mm	Approx. 110.1x64.5x5.7(1.30) cm	Approx. 110.1x64.5x5.7(1.30) cm	Approx. 1101x645x57(13) mm
	TV with Stand (WxHxD)	110.1x70.4x26.0 cm	1101x704x260 mm / 43 3/8 x 27 3/4 x 10 1/4 inch	1101x704x260 mm	Approx. 110.1x70.4x26.0 cm	Approx. 110.1x70.4x26.2 cm	Approx. 1101x704x260 mm
	Media Receiver (WxHxD)	-	-	-	-	-	-
	Monitor only (WxHxD)	-	-	-	-	-	-
	Monitor with Stand (WxHxD)	-	-	-	-	-	-
	Media Receiver with Stand (WxHxD)	-	-	-	-	-	-
	Satellite Speaker (WxHxD)	-	-	-	-	-	-
WEIGHT	Stand Width	71.9 cm	719 mm / 28 3/8 inch	719 mm	Approx. 71.9 cm	Approx. 68.7 cm	Approx. 719 mm
	YESA Hole Pitch	20.0x20.0 cm	200x200 mm / 7 7/8 x 7 7/8 inch	200x200 mm	20.0x20.0 cm	20.0x20.0 cm	200x200 mm
	TV Only	11.8 Kg	11.8 Kg / 26 lb	11.8 Kg	Approx. 11.8 Kg	Approx. 11.8 Kg	Approx. 11.8 Kg
Remarks	TV With Stand	12.4 Kg	12.4 Kg / 27.4 lb	12.4 Kg	Approx. 12.4 Kg	Approx. 12.4 Kg	Approx. 12.4 Kg
	Media Receiver	-	-	-	-	-	-
	Monitor Only	-	-	-	-	-	-
	Monitor With Stand	-	-	-	-	-	-
	Media Receiver with Stand	-	-	-	-	-	-
Satellite Speaker	-	-	-	-	-	-	

WITH STAND (except KD-49XG8196)

* PLEASE REFER NEXT PAGE FOR REAR COVER TYPE INDICATION

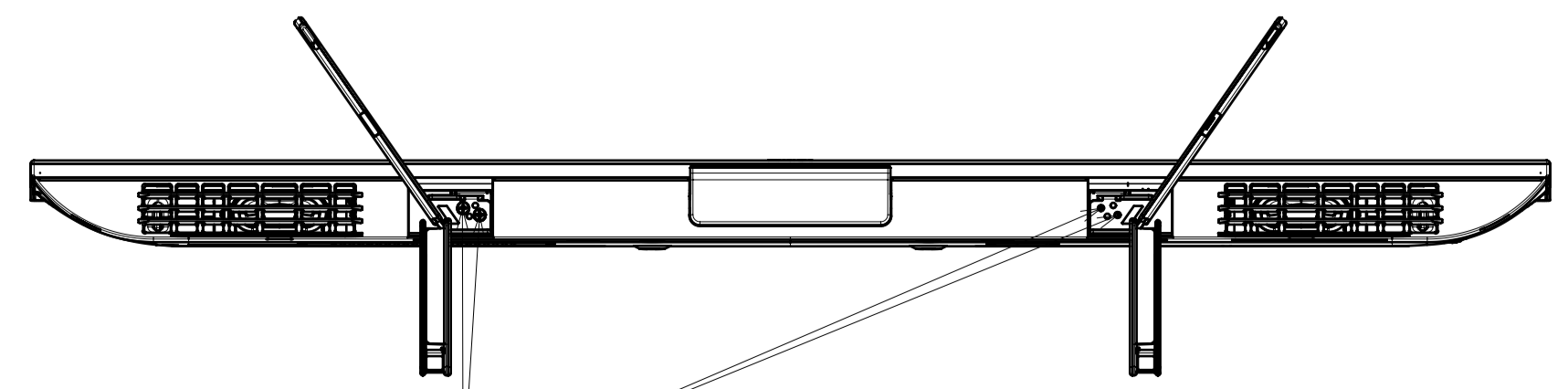
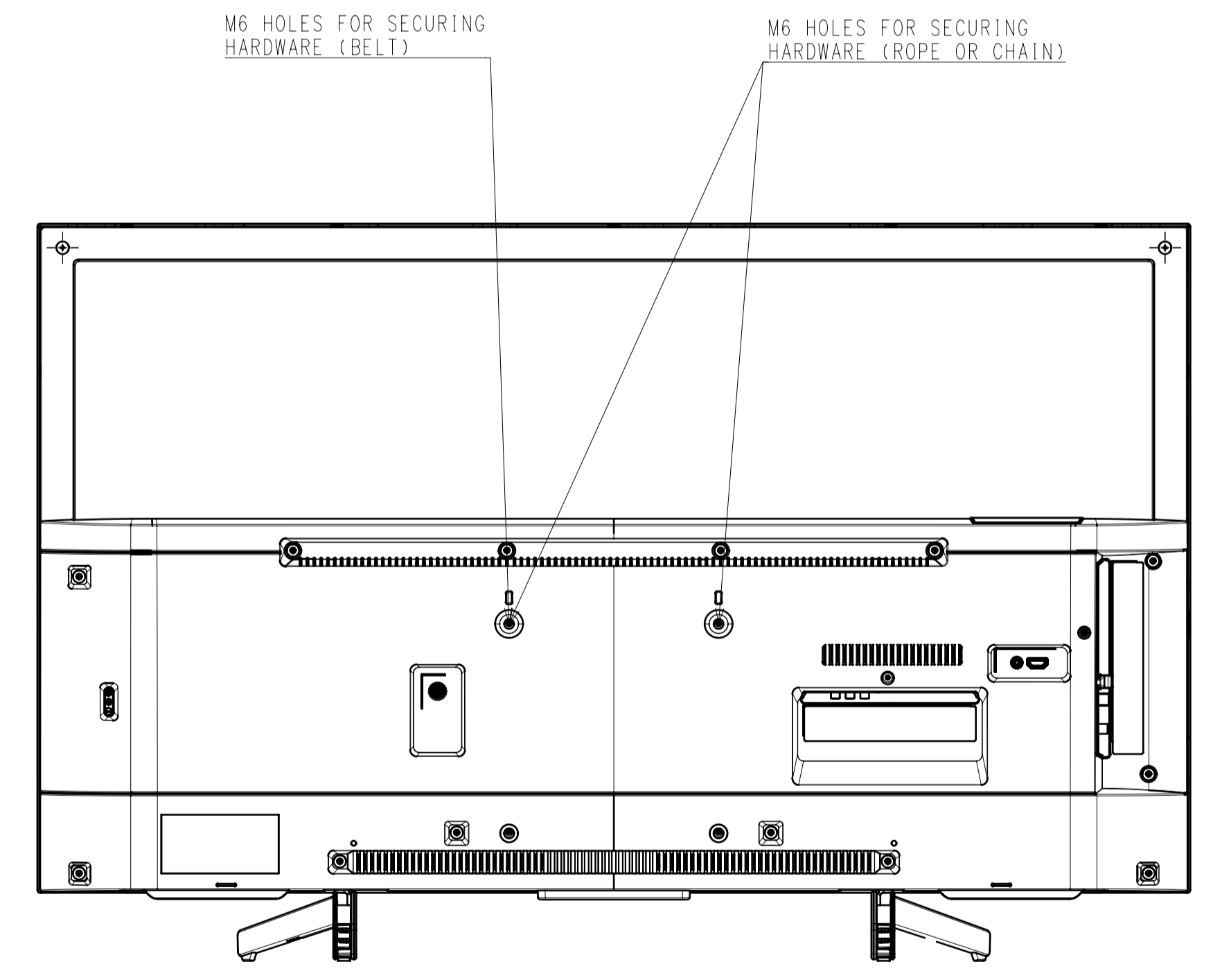
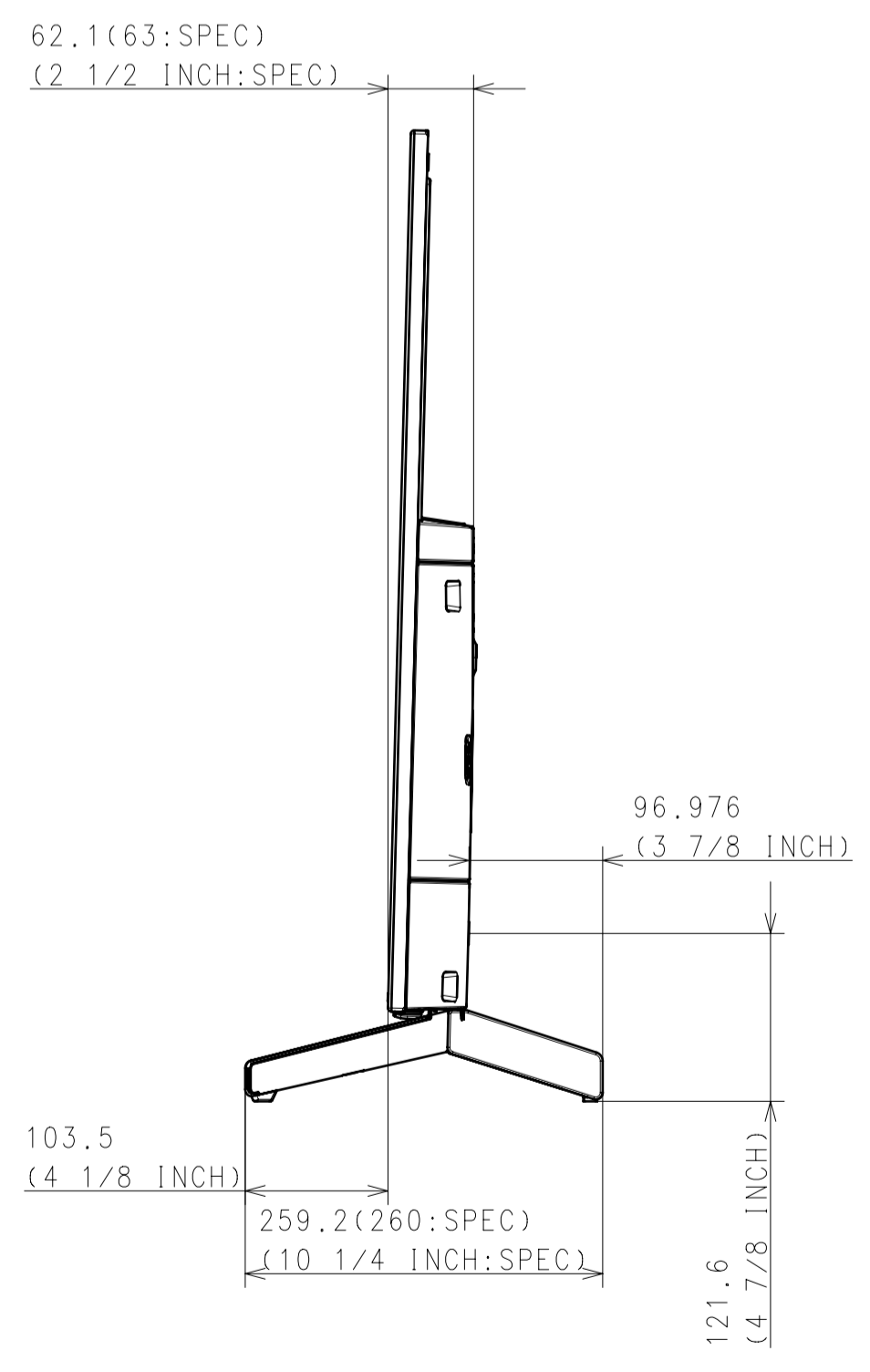
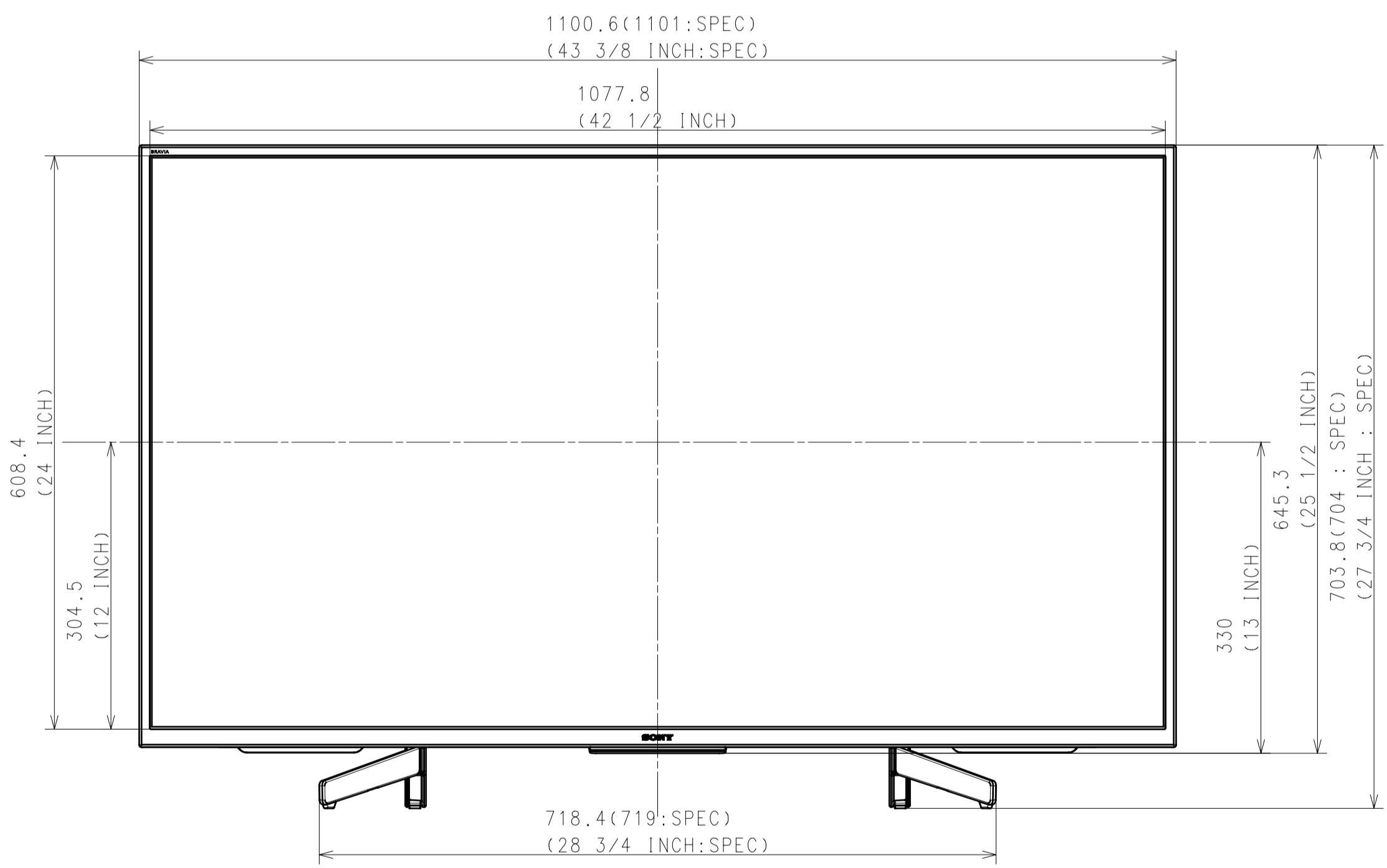
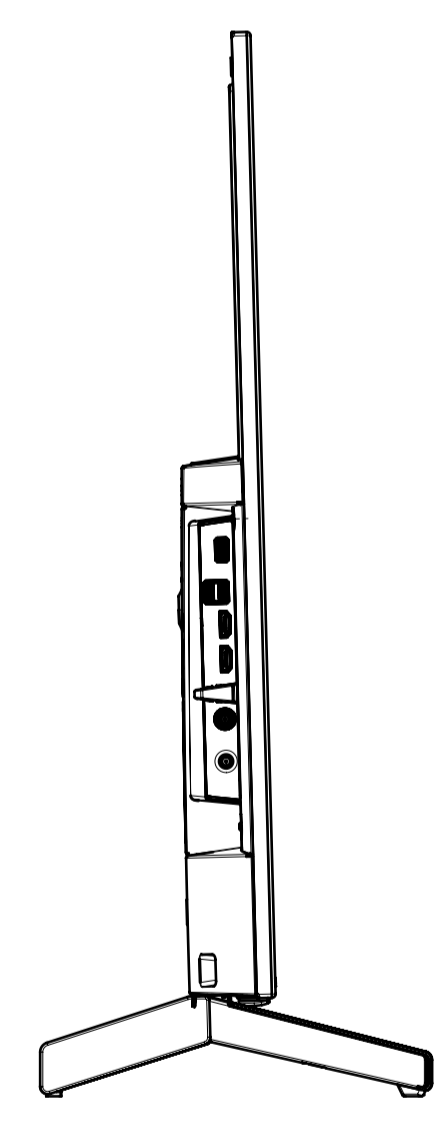
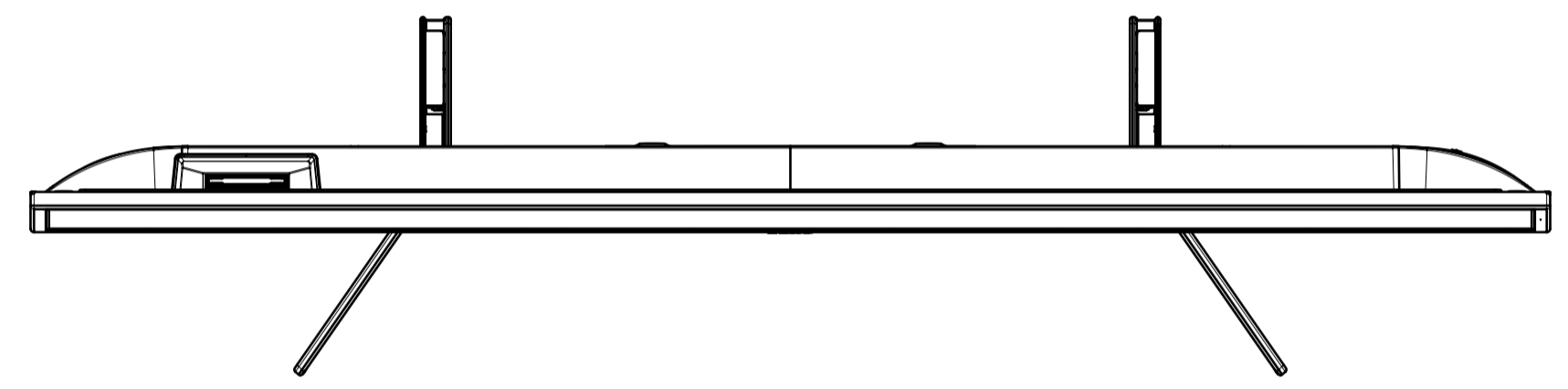

SCREW HOLES FOR STAND

Purchase recycled resins and wire rods only from the business partners that Sony approves as Green Partners.
再生樹脂・電線鋼線はグリーンパートナー認定品から調達すること。

△A						GENERAL TOLERANCE	DATE OF ISSUE
△A							DOCUMENT TYPE
△A							PART
							TOLERANCING DRAWING
							(JIS 0 000150 PARTS)
HISTORY	SUFFIX	RELEASE NO.	REVISION	SIGN.		MATERIAL COLOR	FINISH COLOR
V. COUNT	PREL. NO.	DATE					
LEGAL OWNER							
Sony Corporation							
RESPONSIBLE DEPARTMENT		ORIGINAL MODEL	DESCRIPTION				
PLANNED BY	CHECKED BY	APPROVED BY	SCALE	TENTATIVE MODEL	49(X800) EXTERIOR VIEW DRAWING		
DRAWN BY			1:5		49(X800) EXTERIOR VIEW DRAWING		
			PREL. METHOD	SIZE	UNIT	PART NO.	SUFFIX
			A1	mm			REV. NO.
							1/4

WITH STAND (KD-49XG8196)

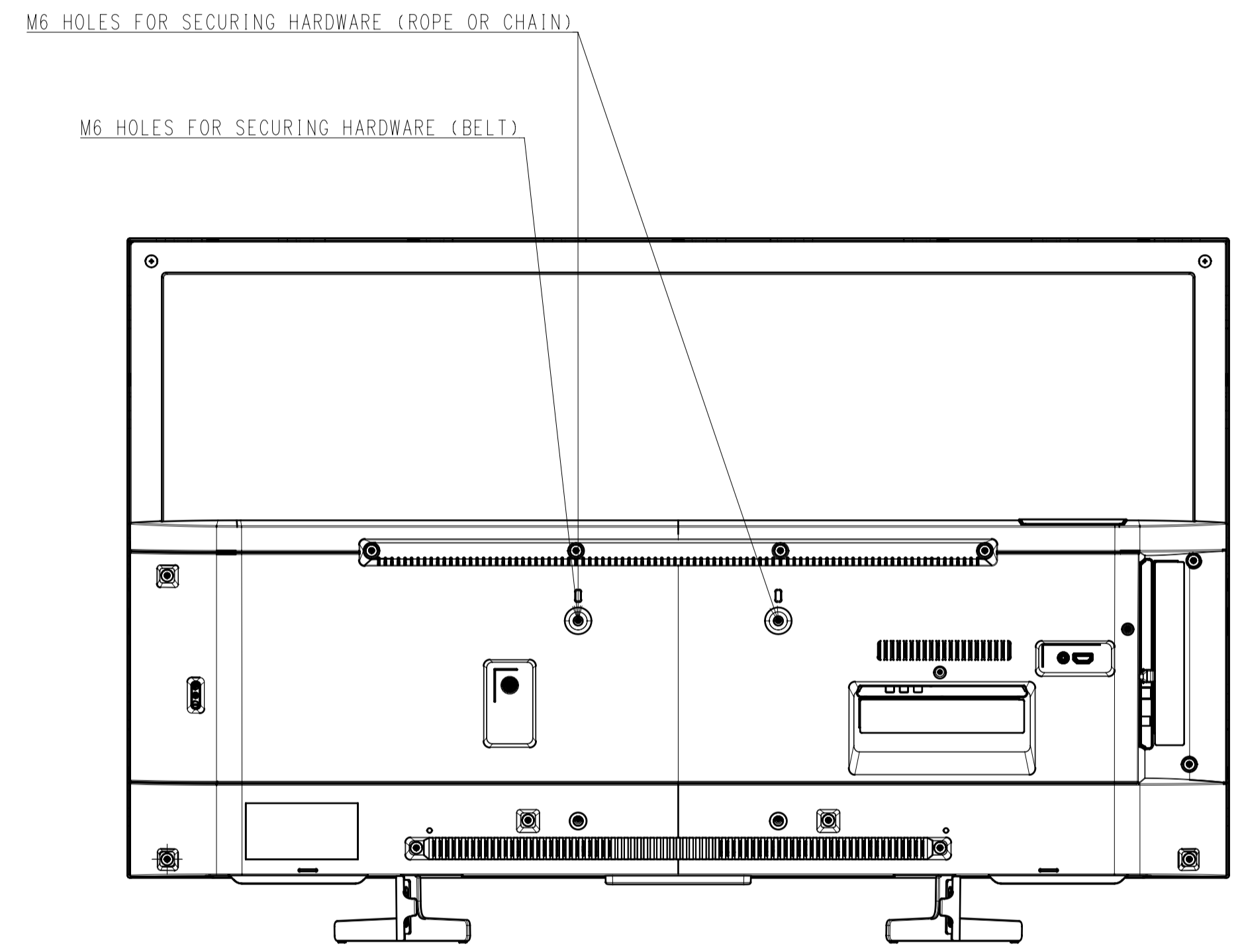
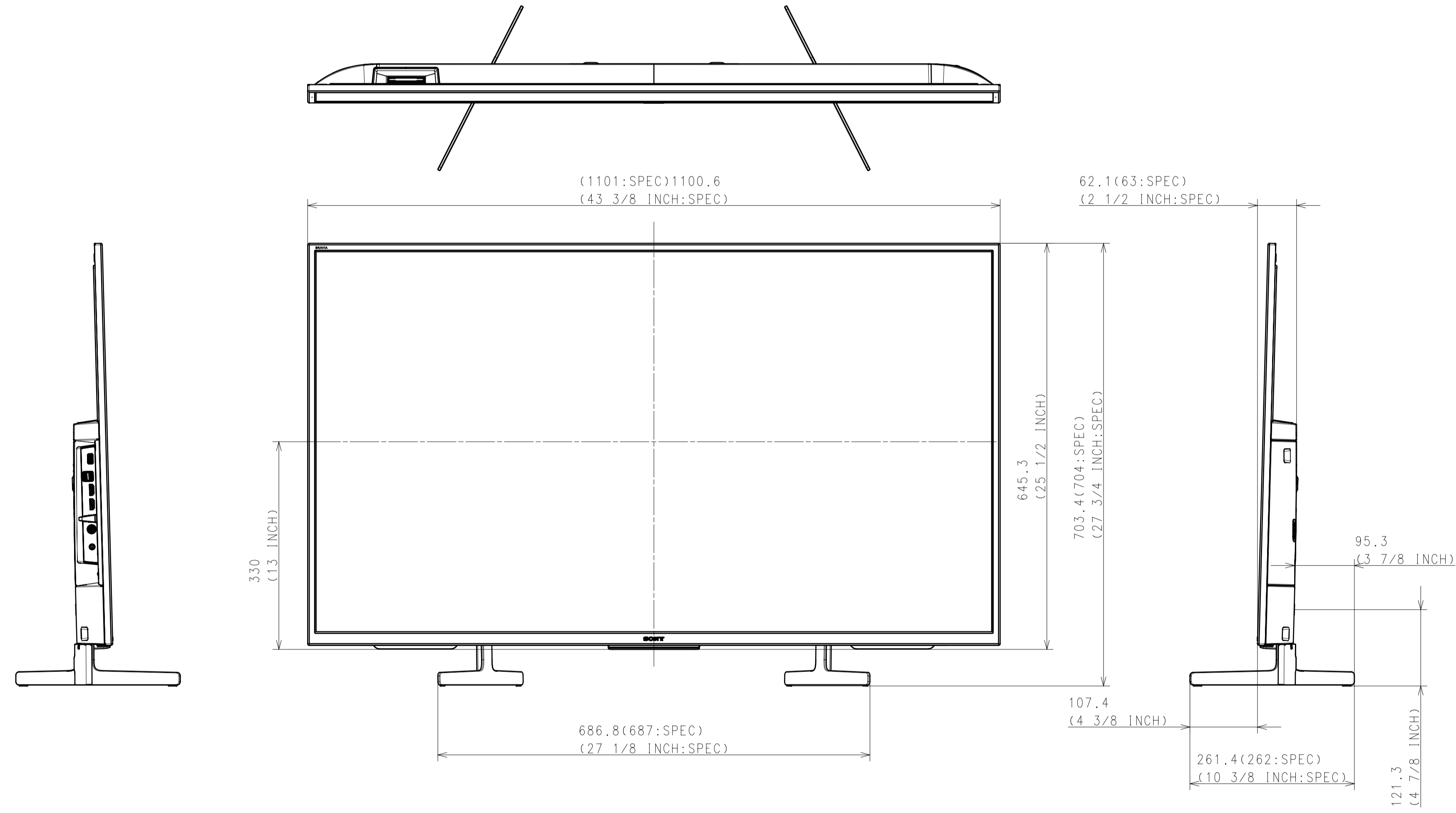

DESCRIPTION 1	LEGAL OWNER	SCALE
49(X800) EXTERIOR VIEW DRAWING	Sony Corporation	1:5
DESCRIPTION 2	PART NO.	SHEET/PAGES
49(X800) EXTERIOR VIEW DRAWING		2 / 4

ALL AREA EXCEPT EUROPE MODELS

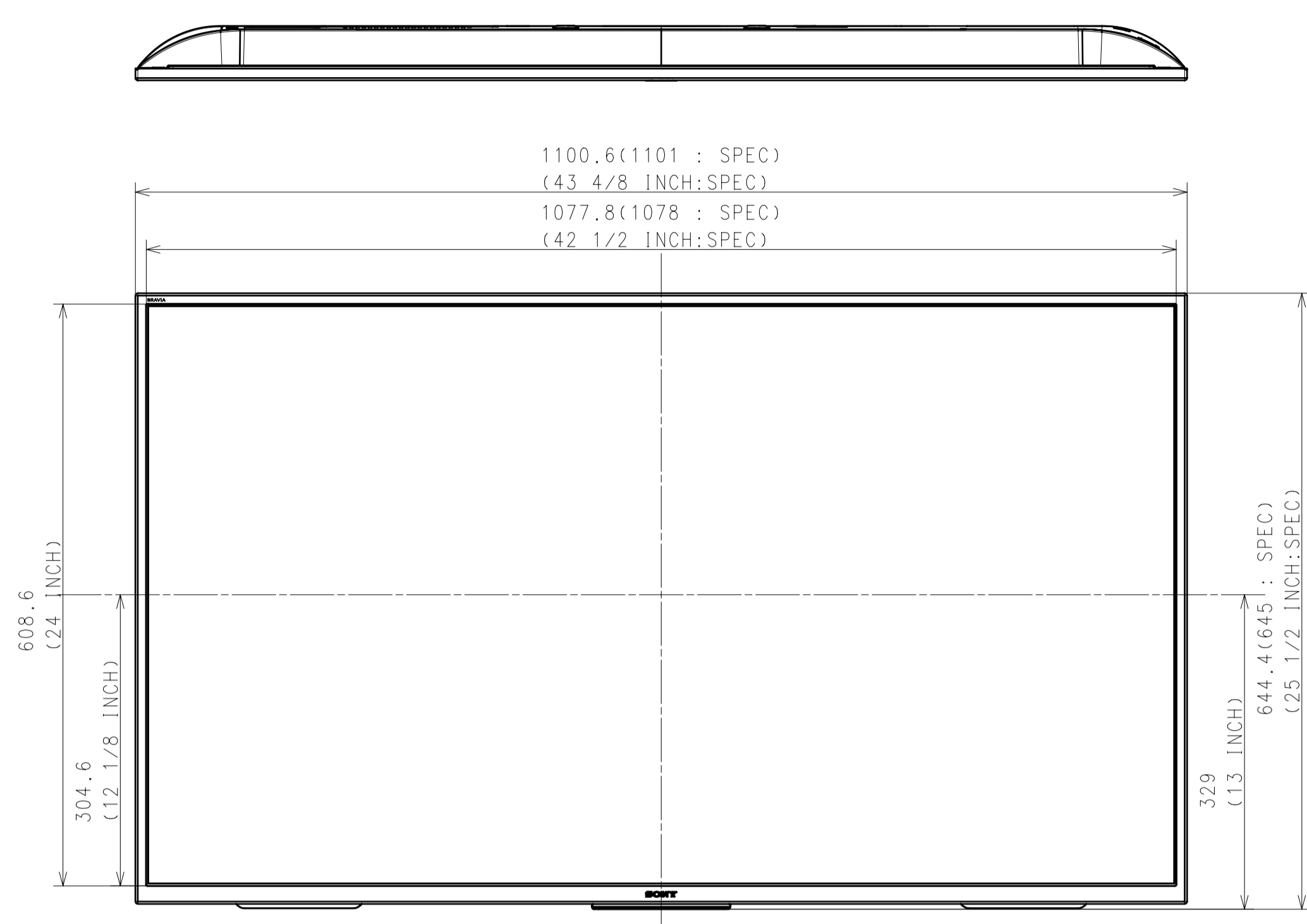

56.8(57 : SPEC)
(2 1/4 INCH:SPEC)
12.5(13 : SPEC)
(17/32 INCH:SPEC)

M6 HOLES FOR WALLMOUNT
#REFER INSTRUCTIONS MANUAL FOR SCREW LENGTH INFORMATION

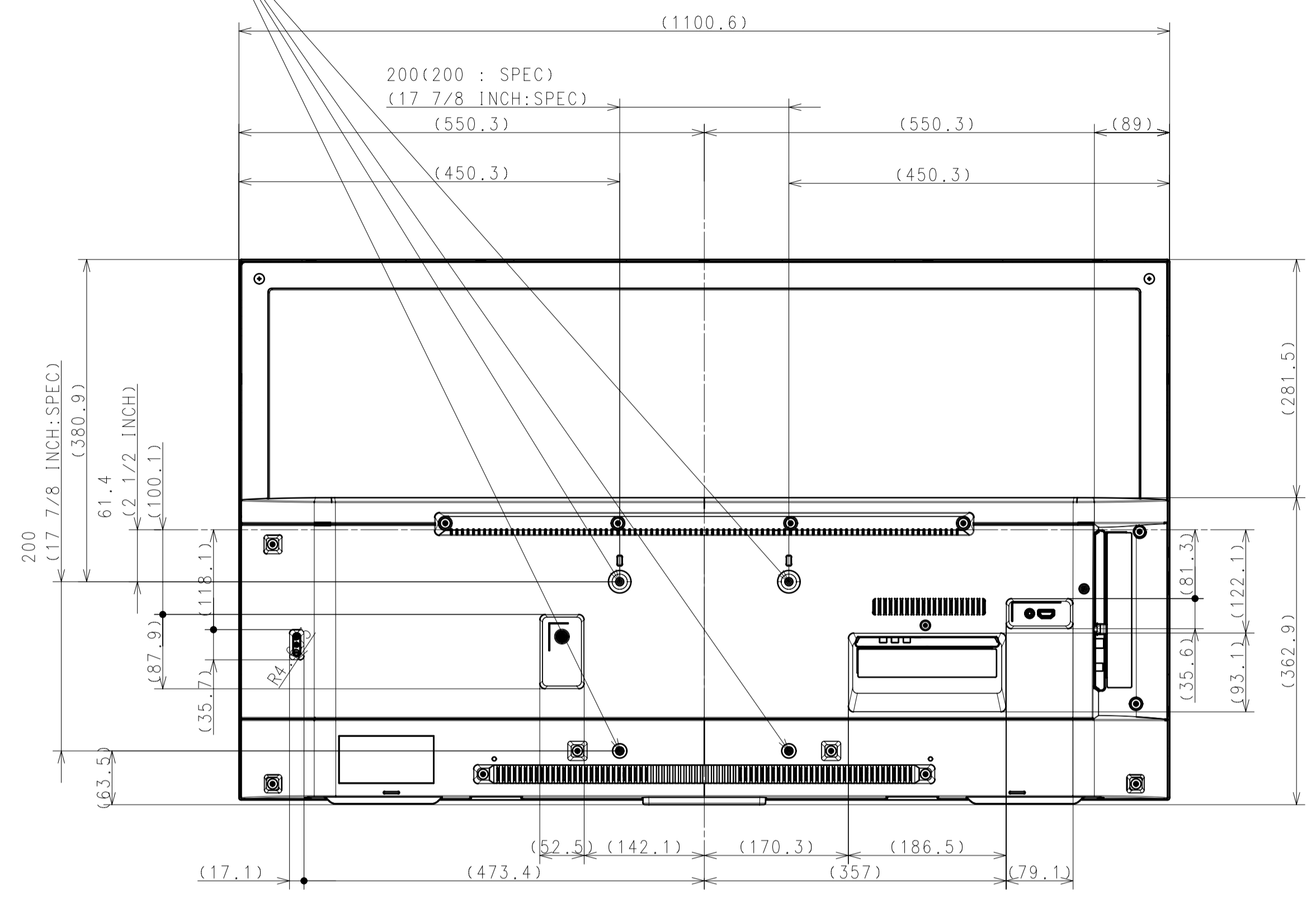

EUROPE MODELS

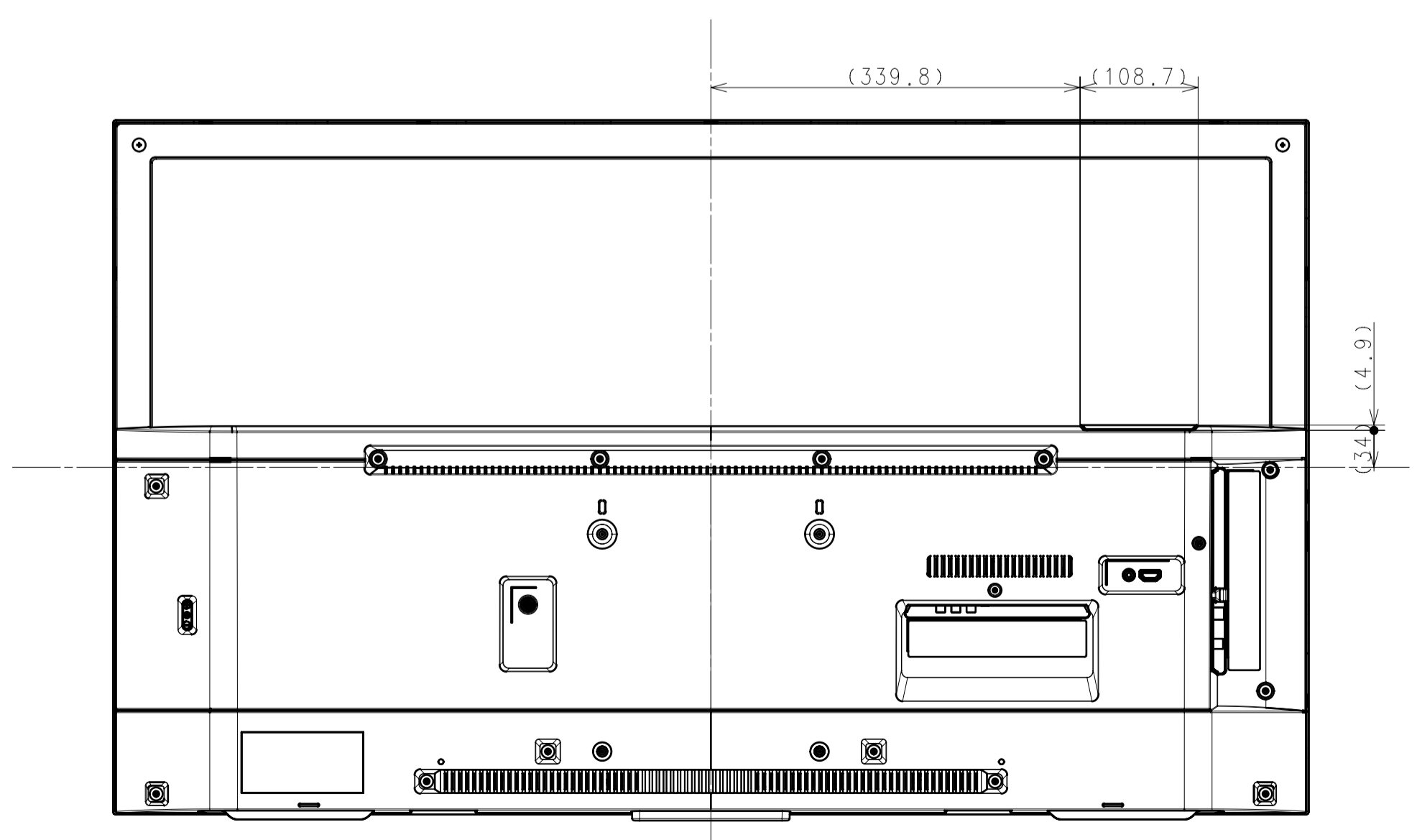
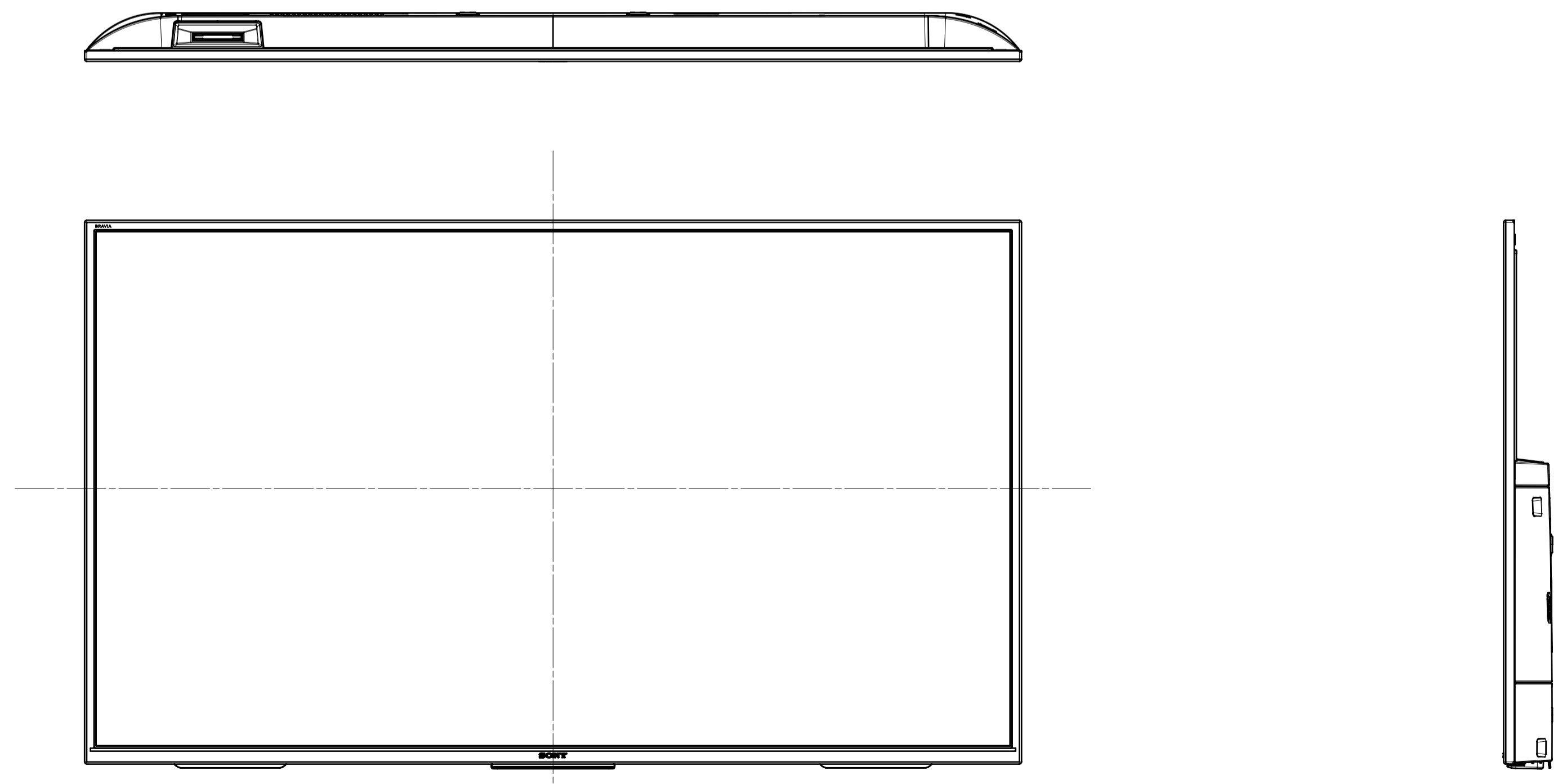

DESCRIPTION 1 49(X800) EXTERIOR VIEW DRAWING	LEGAL OWNER Sony Corporation	SCALE 1:5
DESCRIPTION 2 49(X800) EXTERIOR VIEW DRAWING	PART NO.	SHEET/PAGES 3 / 4

SU-WL450 SLIM

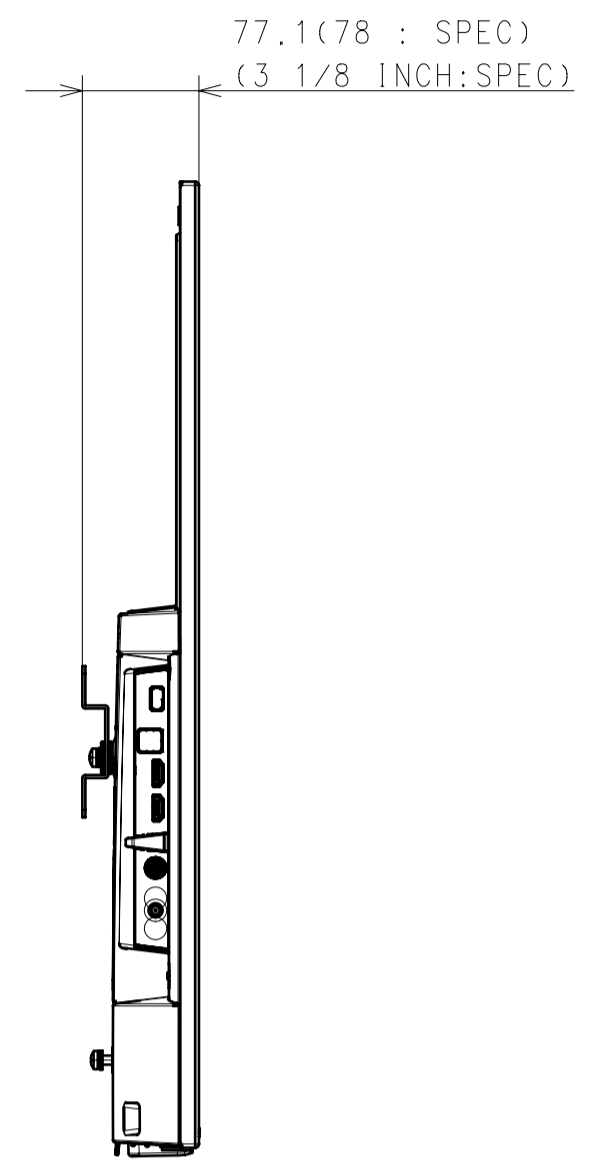
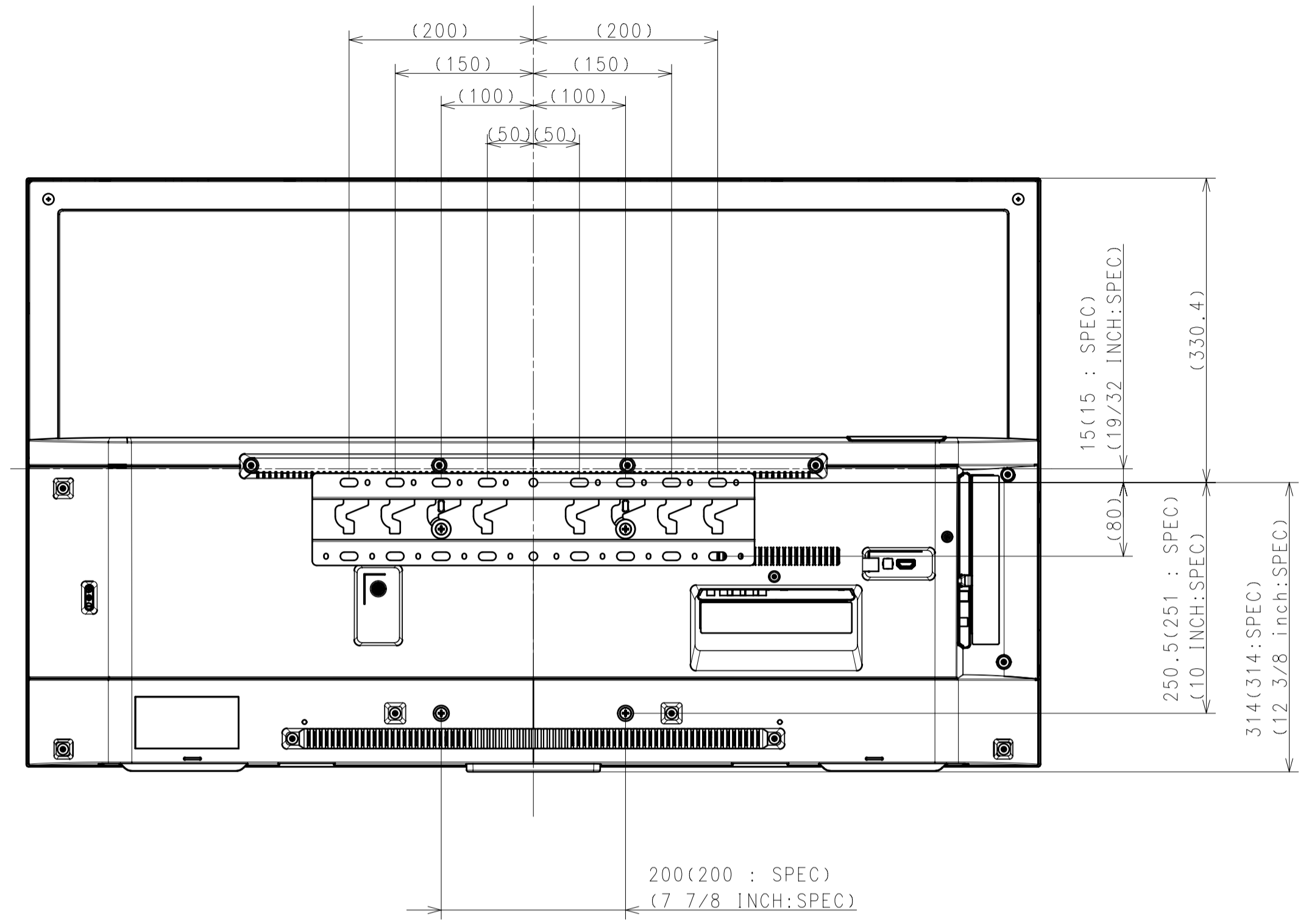

SU-WL450 STANDARD

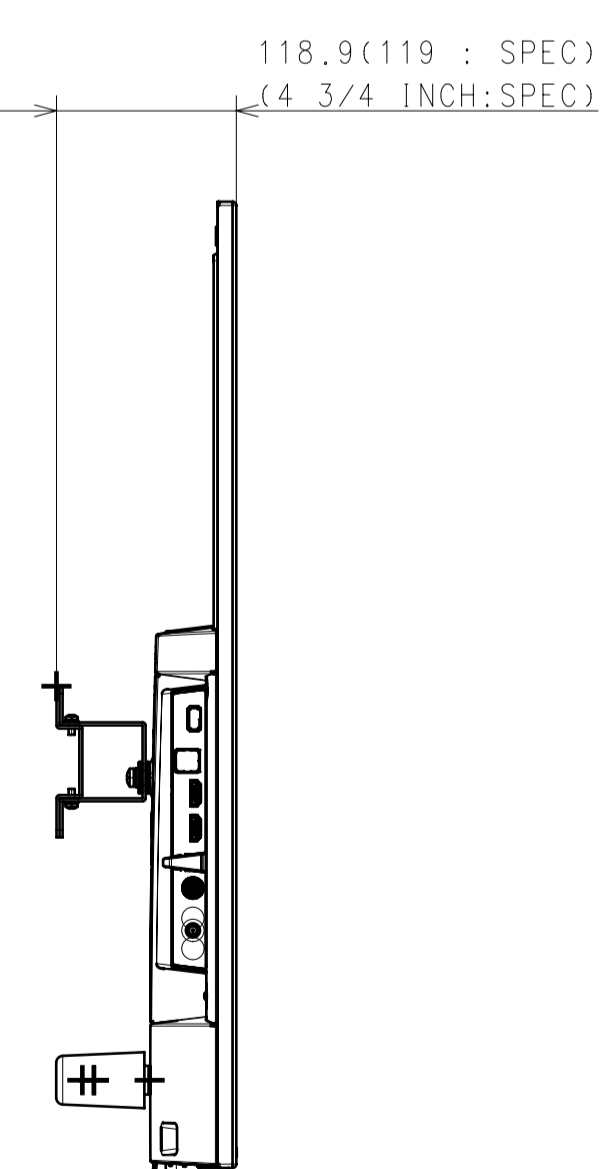
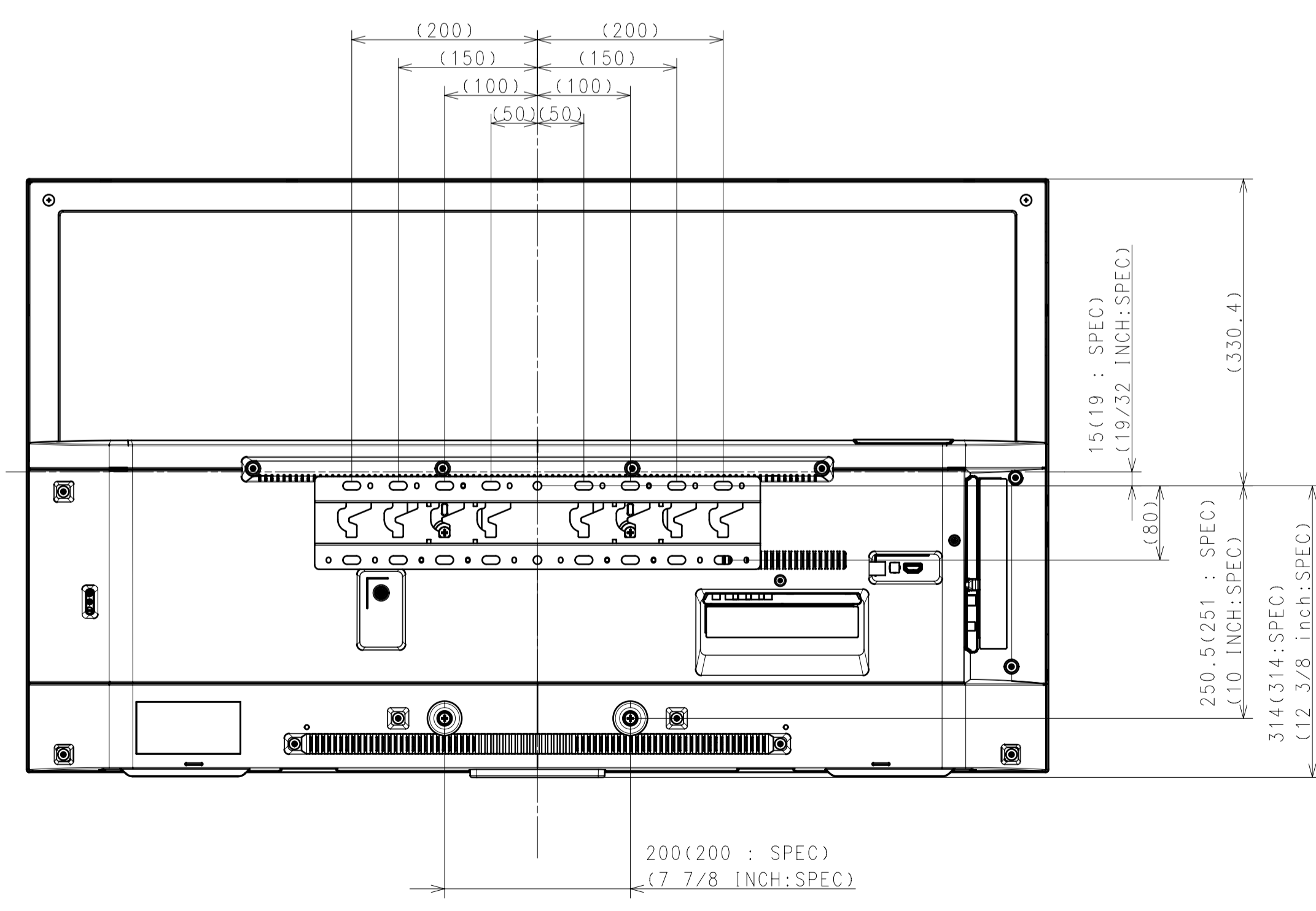

DESCRIPTION 1 49(X800) EXTERIOR VEIW DRAWING	LEGAL OWNER Sony Corporation	SCALE 1:5
DESCRIPTION 2 49(X800) EXTERIOR VEIW DRAWING	PART NO.	SHEET/PAGES 4 / 4