

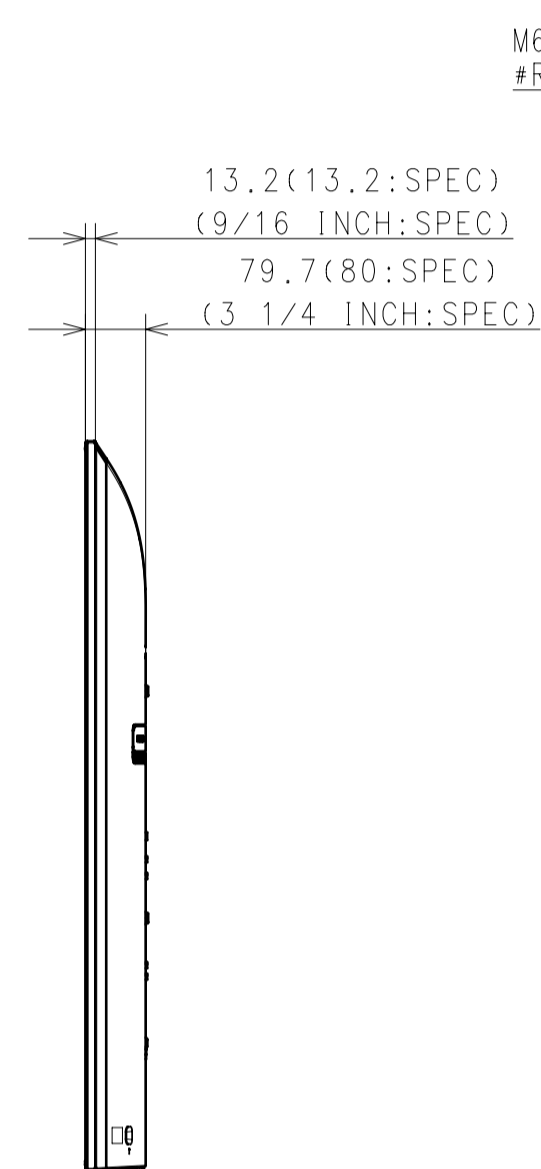

WITHOUT STAND

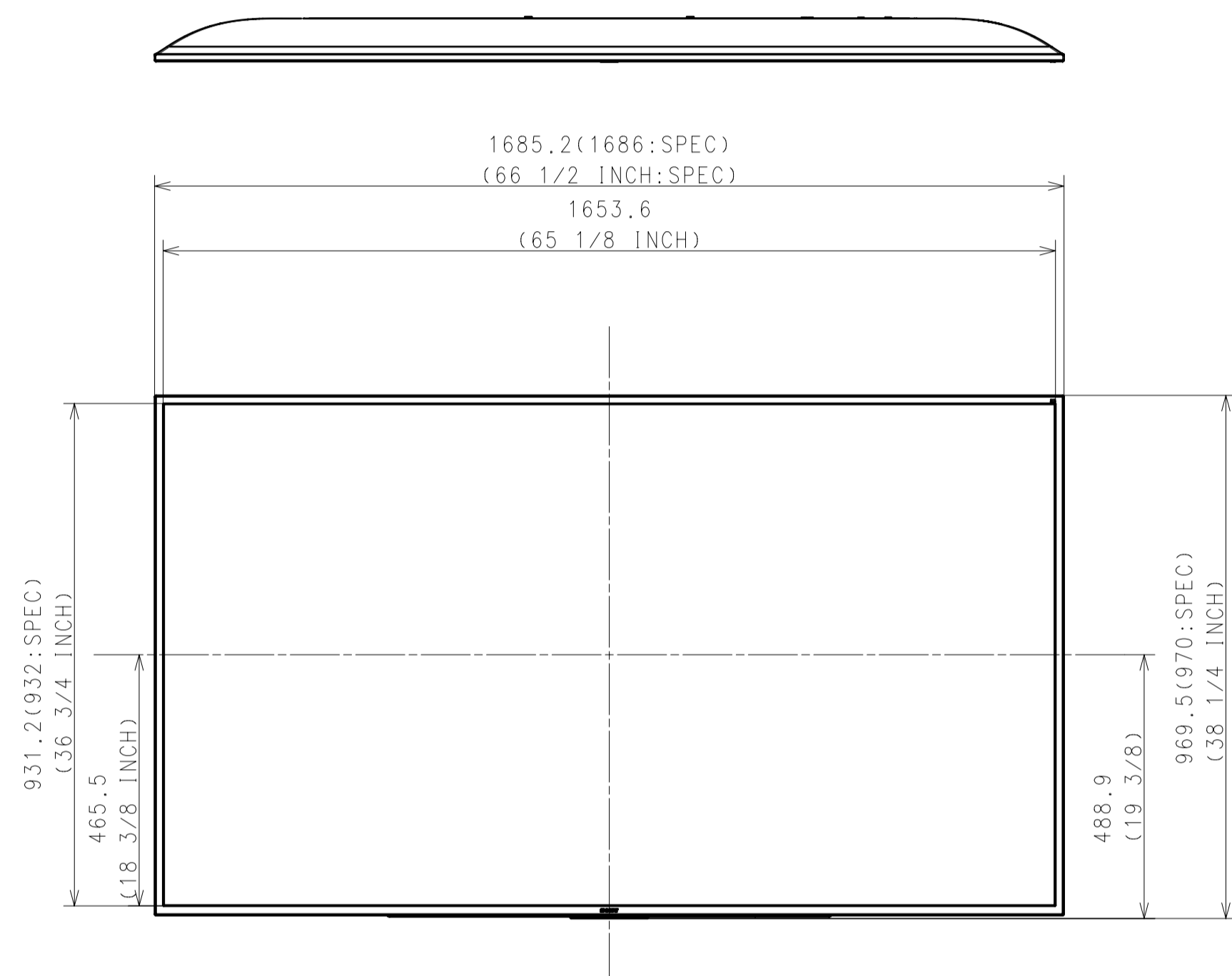

M6 HOLES FOR WALLMOUNT  
#REFER INSTRUCTIONS MANUAL FOR SCREW LENGTH INFORMATION

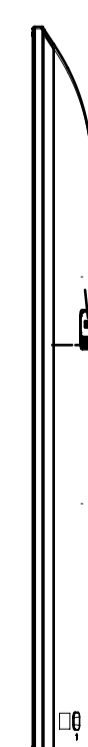
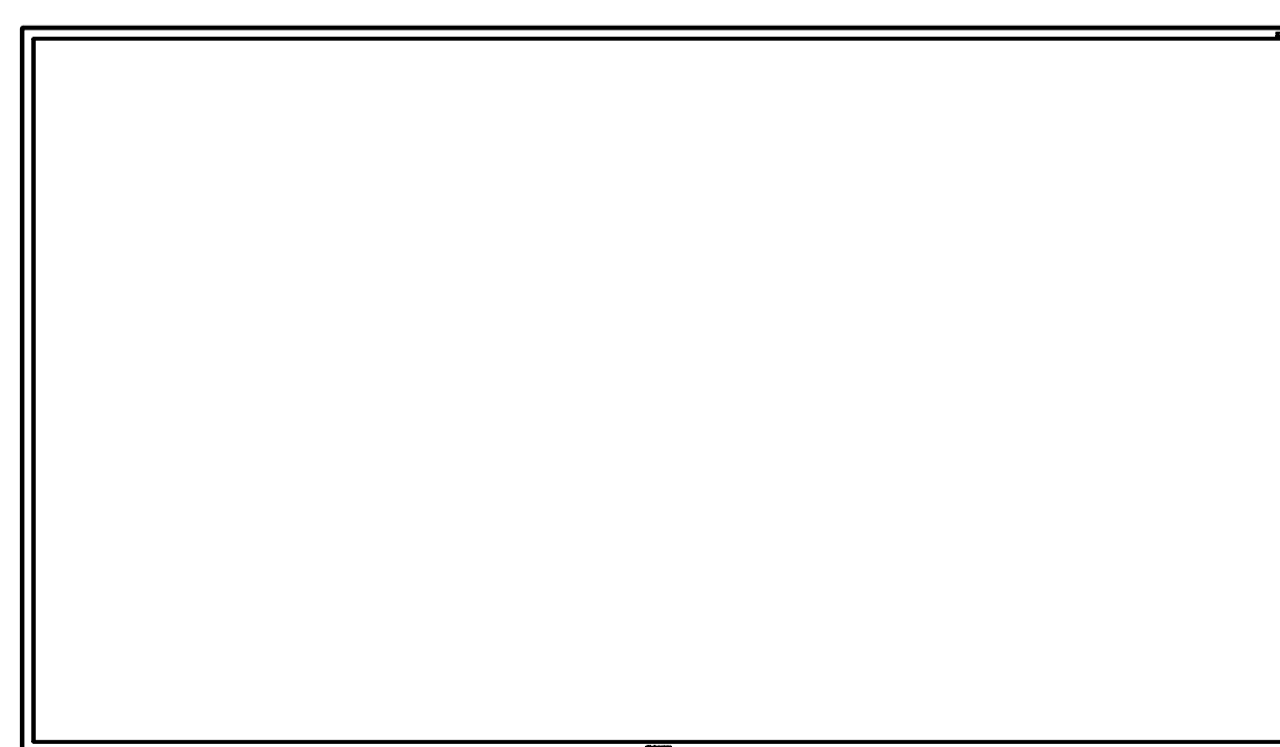
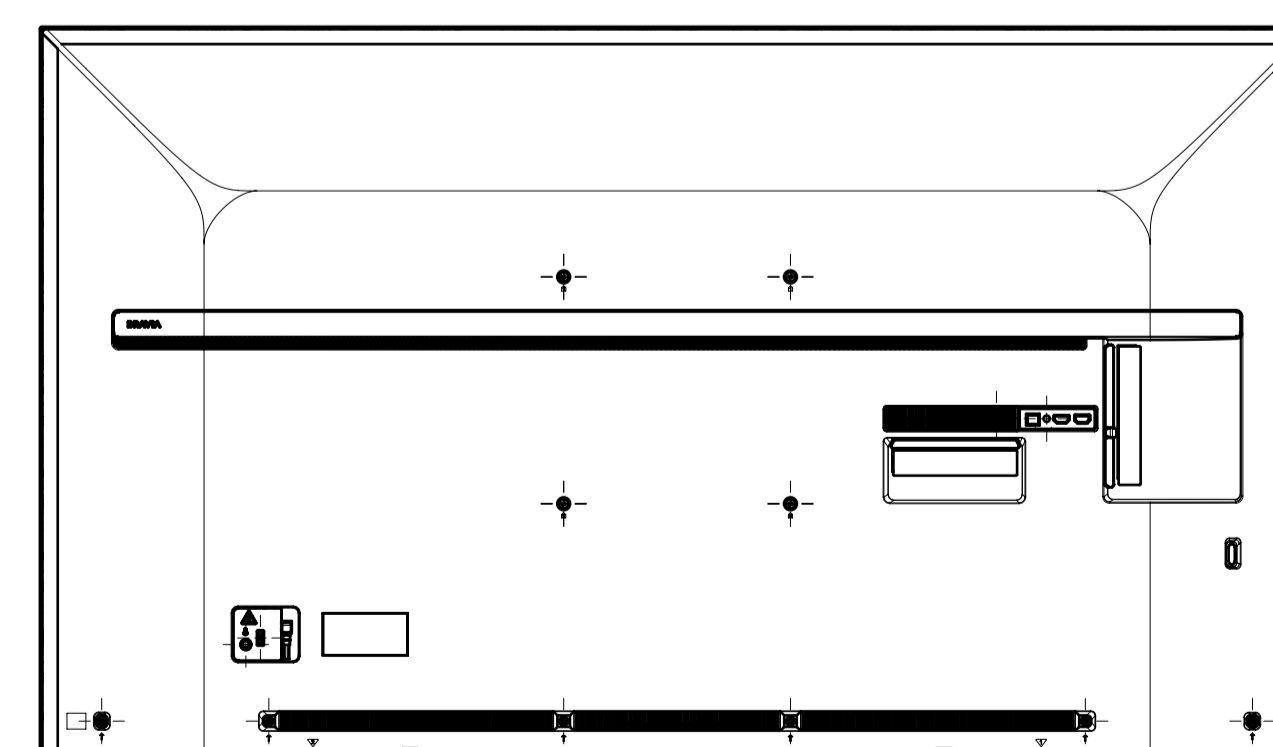
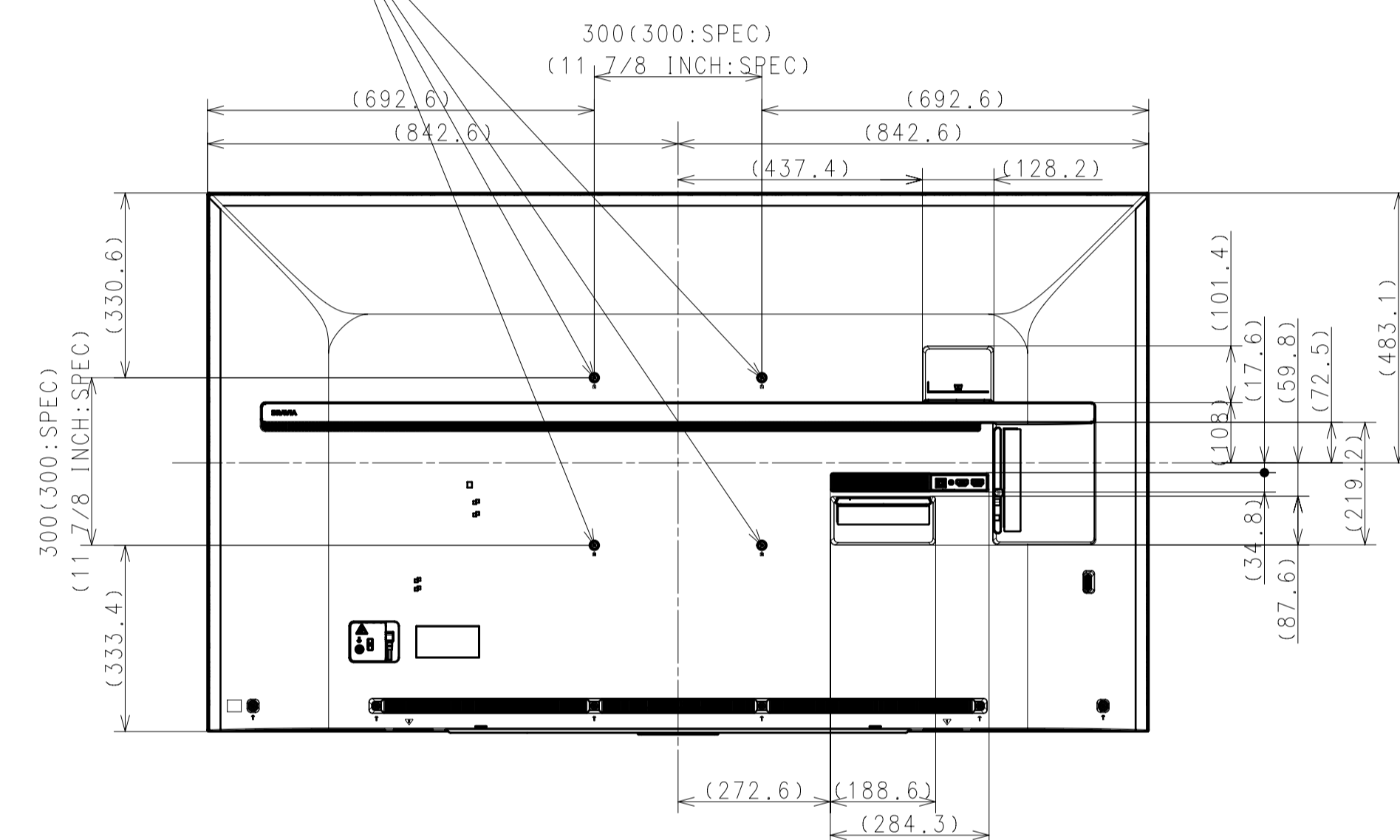

DESCRIPTION 1 75 (X800) EXTERIOR VIEW	LEGAL OWNER Sony Corporation	SCALE 1:10
DESCRIPTION 2 75 (X800) EXTERIOR VIEW	PART NO.	SHEET/PAGES 2 / 3

SU\_WL450 STANDARD

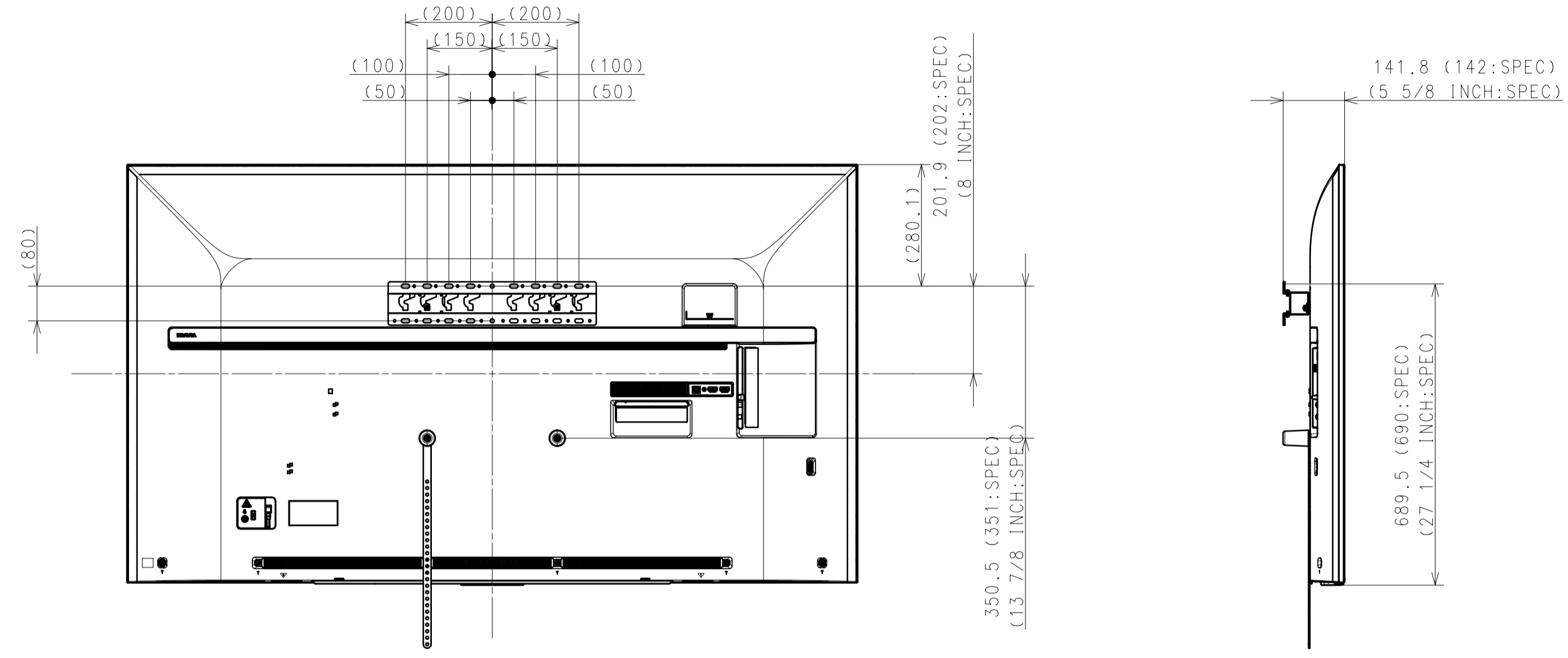

SU\_WL450 SLIM

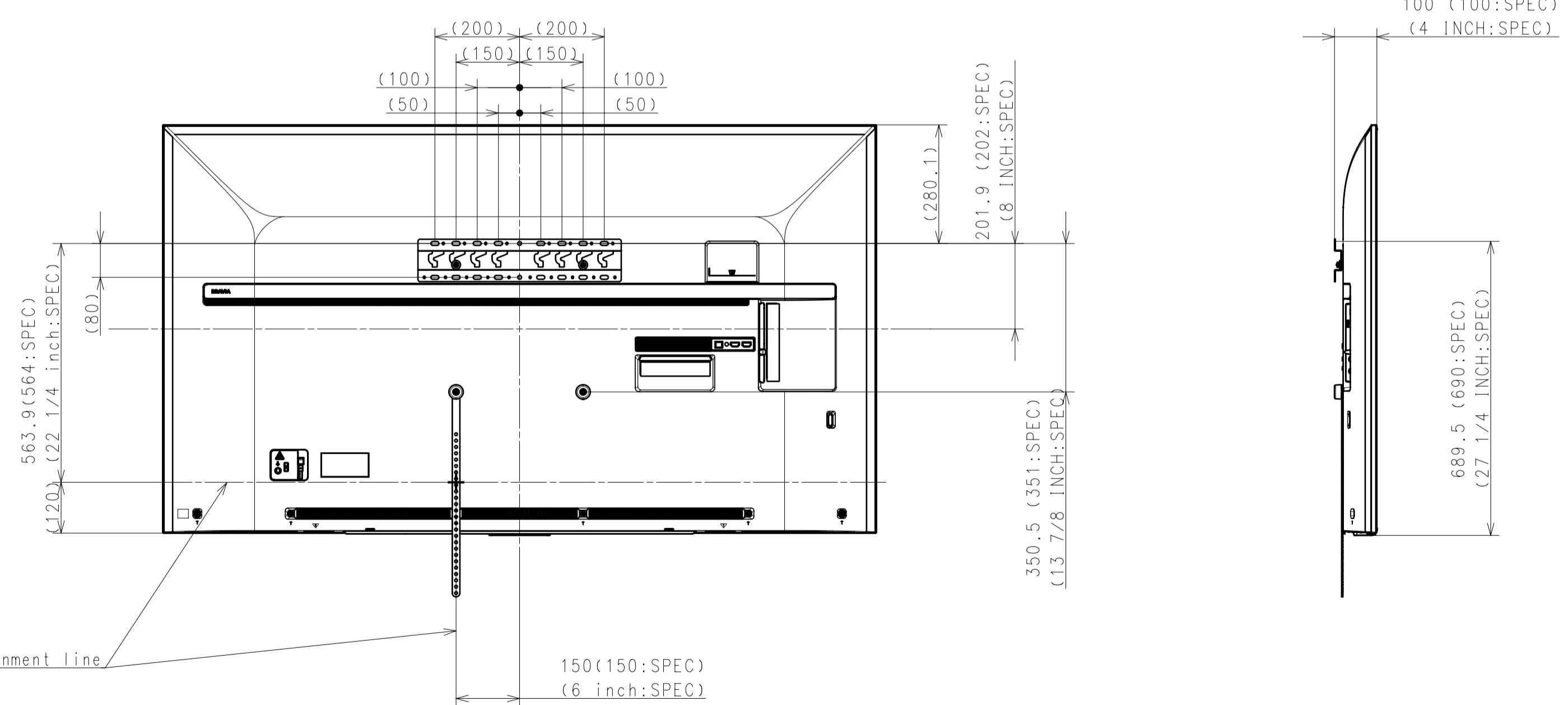

SU-WL450  
Masking Tape Alignment line

DESCRIPTION 1	LEGAL OWNER	SCALE
75 (X800) EXTERIOR VIEW	Sony Corporation	1:10
DESCRIPTION 2	PART NO.	SHEET/PAGES
75 (X800) EXTERIOR VIEW		3 / 3