

Area	NORTH AMERICA	LATIN AMERICA	EUROPE	GENERAL AREA	CHINA
Model Name	XBR-85X900F	XBR-85X905F	-	KD-85X9000F	KD-85X9000F
SV No.	SV-34077	SV-34098	-	SV-34190	SV-34268
DIMENSION					
TV only (WxHxD)	1910x1096x73 mm / 75 1/4 x 43 1/4 x 2 7/8 inch	1910x1096x73 mm	-	Approx. 1910x1096x73 mm	Approx. 1910x1096x73 mm
TV with Stand (WxHxD)	1910x1176x396 mm / 75 1/4 x 46 3/8 x 15 5/8 inch	1910x1176x396 mm	-	Approx. 1910x1176x396 mm	Approx. 1910x1176x396 mm
Media Receiver (WxHxD)	-	-	-	-	-
Monitor only (WxHxD)	-	-	-	-	-
Monitor with Stand (WxHxD)	-	-	-	-	-
Media Receiver with Stand (WxHxD)	-	-	-	-	-
Satellite Speaker (WxHxD)	-	-	-	-	-
Stand Width	1733 mm / 68 1/4 inch	1733 mm	-	Approx. 1733 mm	Approx. 1733 mm
VESA Hole Pitch	400x400 mm / 15 3/4 x 15 3/4 inch	400x400 mm	-	400x400 mm	400x400 mm
WEIGHT					
TV Only	45.2 Kg / 99.6 lb	45.2 Kg	-	Approx. 45.2 Kg	Approx. 45.2 Kg
TV With Stand	48.2 Kg / 106.2 lb	48.2 Kg	-	Approx. 48.2 Kg	Approx. 48.2 Kg
Media Receiver	-	-	-	-	-
Monitor Only	-	-	-	-	-
Monitor With Stand	-	-	-	-	-
Media Receiver with Stand	-	-	-	-	-
Satellite Speaker	-	-	-	-	-
Remarks					

WITH STAND

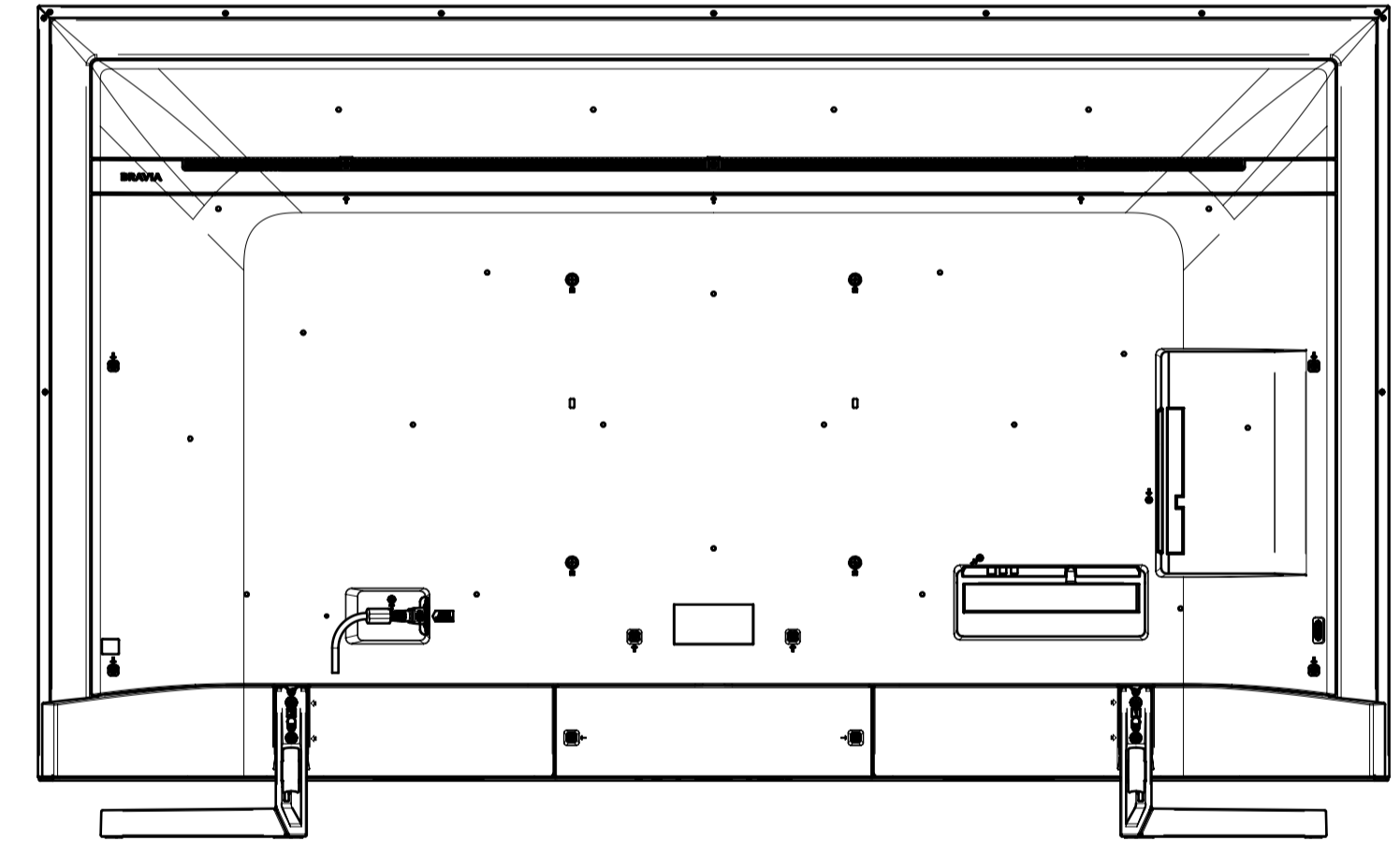
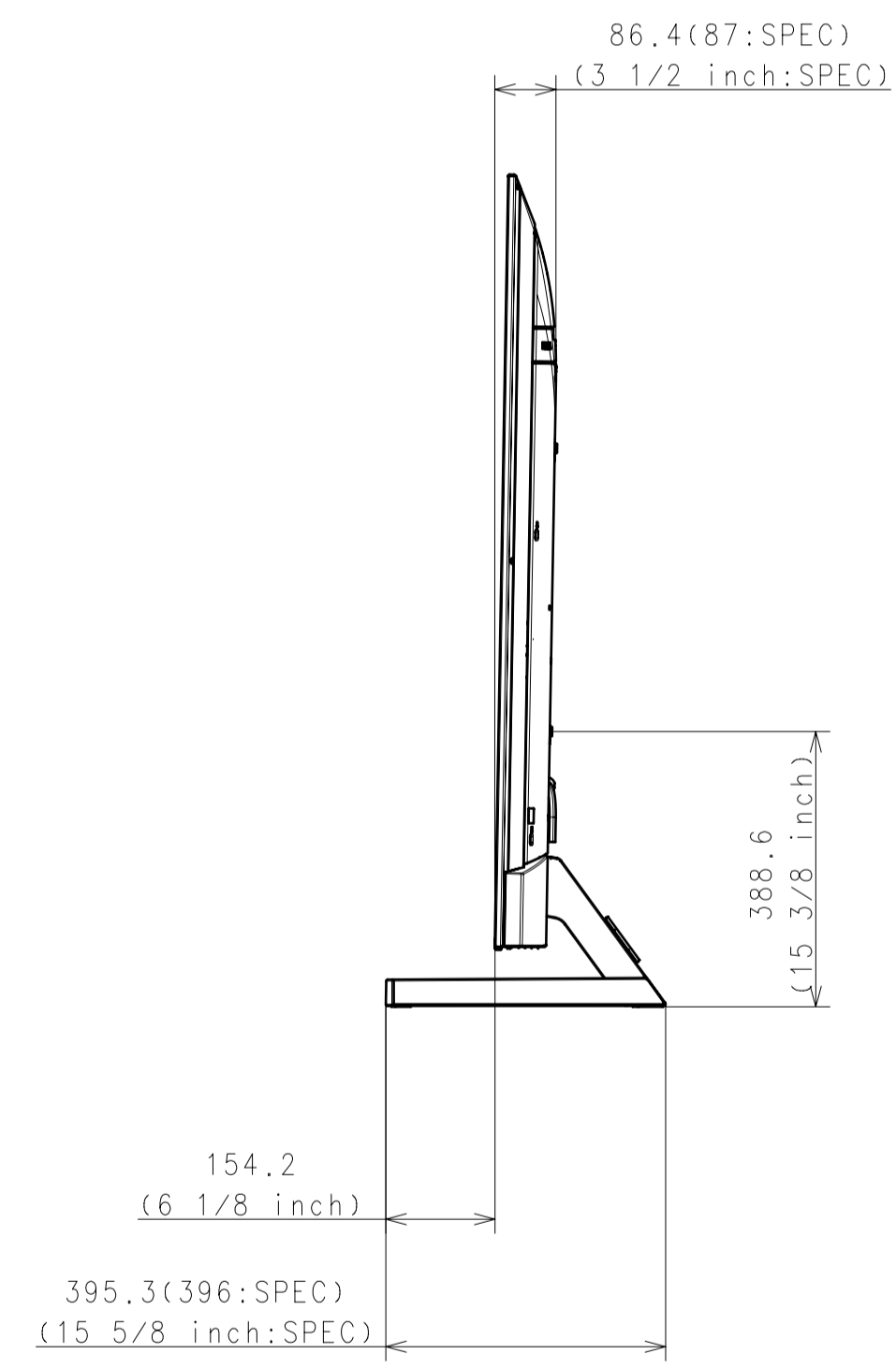
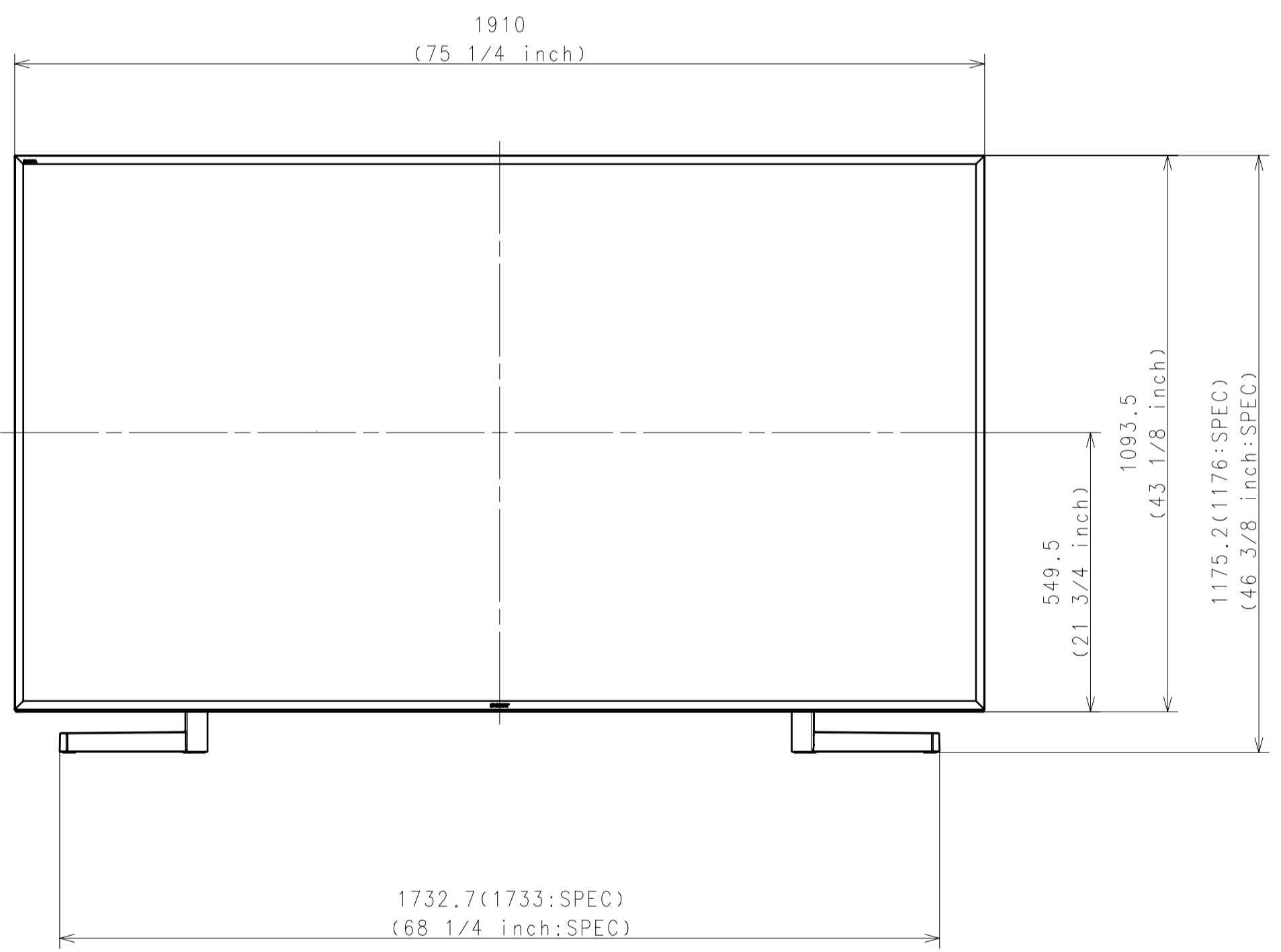
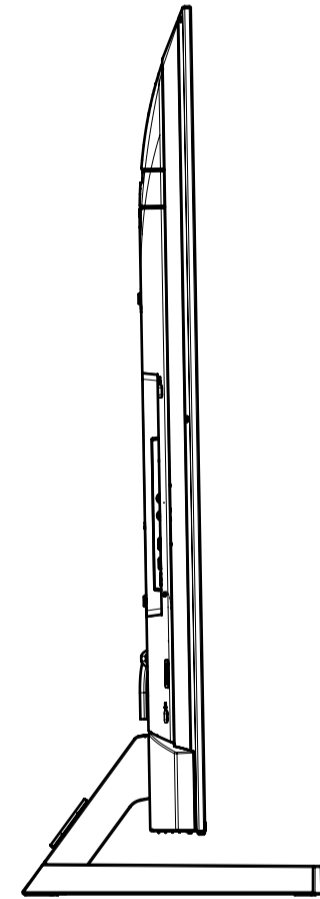
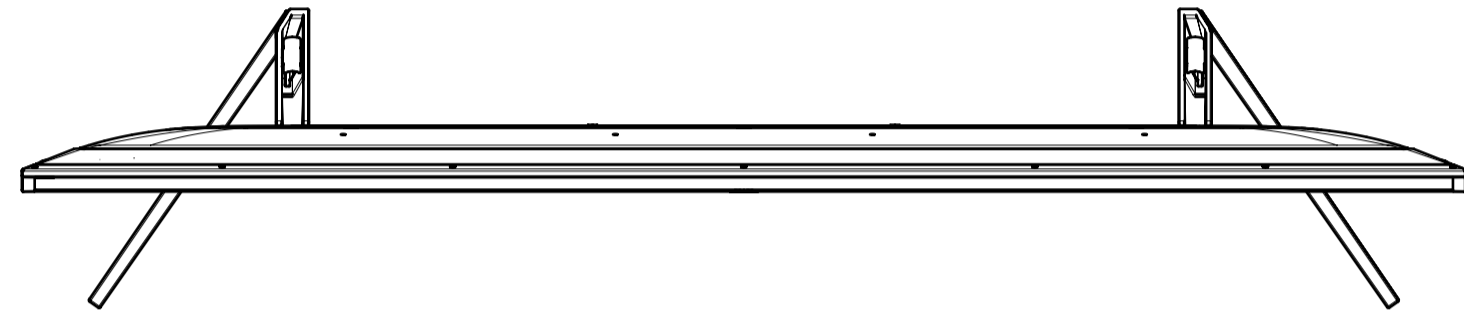

Purchase recycled resins and wire rods only from the business partners that Sony approves as Green Partners.
 再生樹脂・電線電纜はグリーンパートナー 認定製品から調達すること。

GENERAL TOLERANCE	DATE OF ISSUE			
	2017.11.13			
	DOCUMENT TYPE			
	PART			
	TOLERANCING			
	ISO 8015			
MATERIAL COLOR				
FINISH COLOR				
LEGAL OWNER				
Sony Corporation				
RESPONSIBLE DEPARTMENT	SIZE	UNIT	ORIGINAL MODEL	DESCRIPTION
SVP TV B Div PD Dept.3	A1	mm	85 (X9000F)	EXTERIOR VIEW
PLANNED BY	CHECKED BY	APPROVED BY	SCALE	TENTATIVE MODEL
2017.11.13			1:10	85 (X9000F) EXTERIOR VIEW
DESIGNED BY	REV. METHOD	TENTATIVE PART NO.	PART NO.	SHEET/PAGES
2017.11.13				1 / 2

WITHOUT STAND

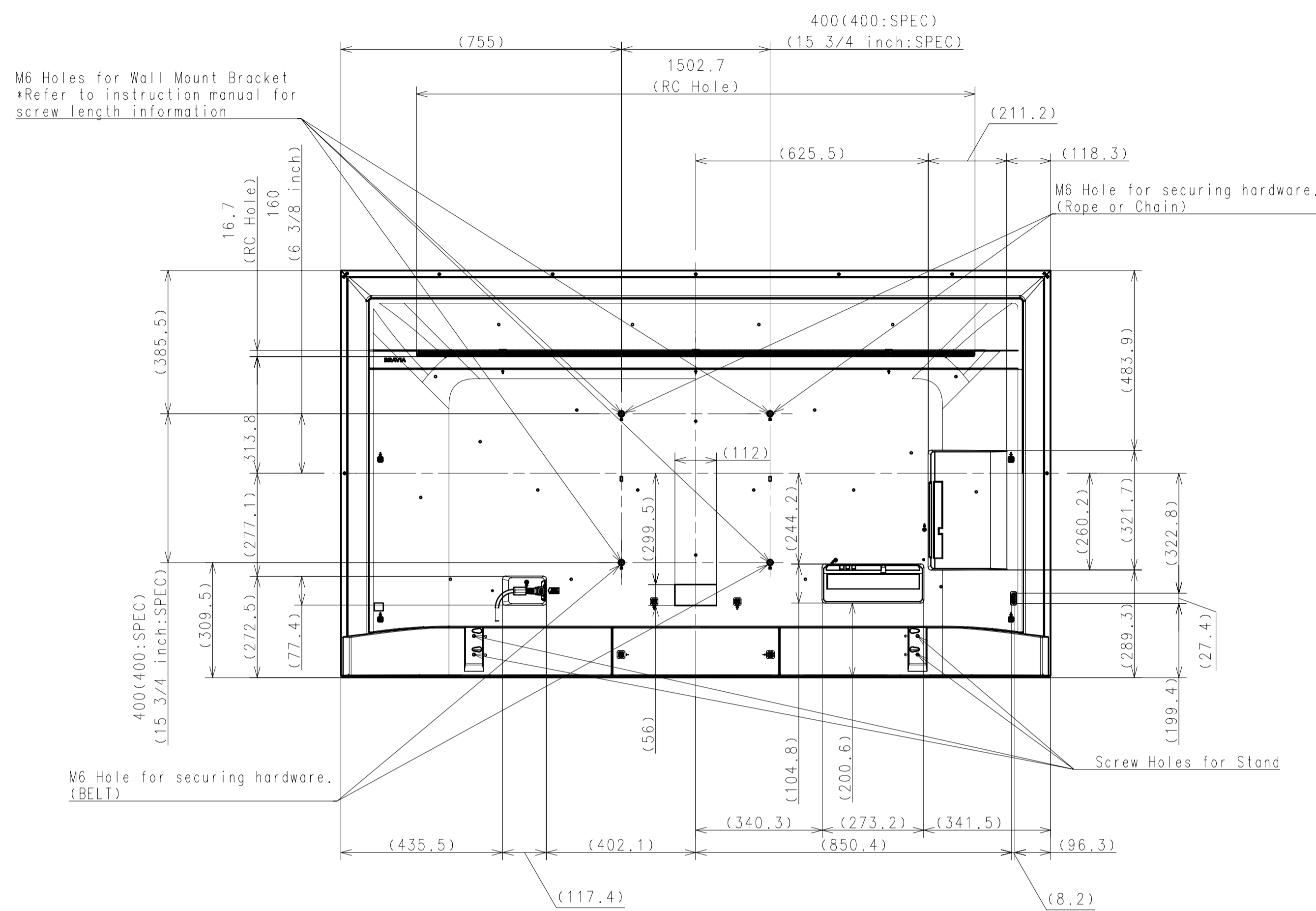
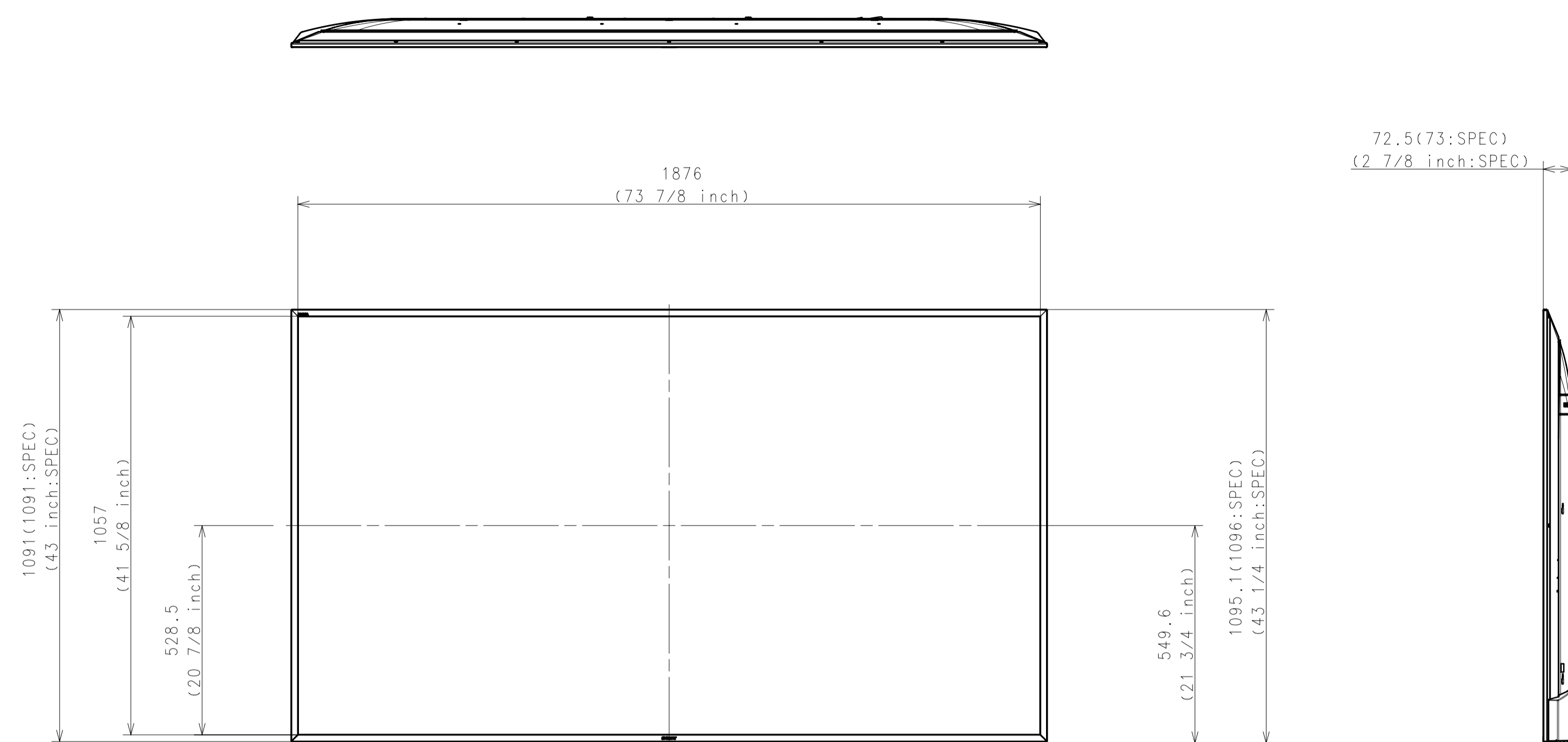

SU-WL500

